



**Fraunhofer**

**ITWM**

S. Repke, N. Marheineke, R. Pinnau

## On adjoint-based optimization of a free surface Stokes flow

© Fraunhofer-Institut für Techno- und Wirtschaftsmathematik ITWM 2010

ISSN 1434-9973

Bericht 186 (2010)

Alle Rechte vorbehalten. Ohne ausdrückliche schriftliche Genehmigung des Herausgebers ist es nicht gestattet, das Buch oder Teile daraus in irgendeiner Form durch Fotokopie, Mikrofilm oder andere Verfahren zu reproduzieren oder in eine für Maschinen, insbesondere Datenverarbeitungsanlagen, verwendbare Sprache zu übertragen. Dasselbe gilt für das Recht der öffentlichen Wiedergabe.

Warennamen werden ohne Gewährleistung der freien Verwendbarkeit benutzt.

Die Veröffentlichungen in der Berichtsreihe des Fraunhofer ITWM können bezogen werden über:

Fraunhofer-Institut für Techno- und  
Wirtschaftsmathematik ITWM  
Fraunhofer-Platz 1

67663 Kaiserslautern  
Germany

Telefon: +49(0)631/3 1600-0  
Telefax: +49(0)631/3 1600-1099  
E-Mail: [info@itwm.fraunhofer.de](mailto:info@itwm.fraunhofer.de)  
Internet: [www.itwm.fraunhofer.de](http://www.itwm.fraunhofer.de)

# Vorwort

Das Tätigkeitsfeld des Fraunhofer-Instituts für Techno- und Wirtschaftsmathematik ITWM umfasst anwendungsnahe Grundlagenforschung, angewandte Forschung sowie Beratung und kundenspezifische Lösungen auf allen Gebieten, die für Techno- und Wirtschaftsmathematik bedeutsam sind.

In der Reihe »Berichte des Fraunhofer ITWM« soll die Arbeit des Instituts kontinuierlich einer interessierten Öffentlichkeit in Industrie, Wirtschaft und Wissenschaft vorgestellt werden. Durch die enge Verzahnung mit dem Fachbereich Mathematik der Universität Kaiserslautern sowie durch zahlreiche Kooperationen mit internationalen Institutionen und Hochschulen in den Bereichen Ausbildung und Forschung ist ein großes Potenzial für Forschungsberichte vorhanden. In die Berichtreihe werden sowohl hervorragende Diplom- und Projektarbeiten und Dissertationen als auch Forschungsberichte der Institutsmitarbeiter und Institutsgäste zu aktuellen Fragen der Techno- und Wirtschaftsmathematik aufgenommen.

Darüber hinaus bietet die Reihe ein Forum für die Berichterstattung über die zahlreichen Kooperationsprojekte des Instituts mit Partnern aus Industrie und Wirtschaft.

Berichterstattung heißt hier Dokumentation des Transfers aktueller Ergebnisse aus mathematischer Forschungs- und Entwicklungsarbeit in industrielle Anwendungen und Softwareprodukte – und umgekehrt, denn Probleme der Praxis generieren neue interessante mathematische Fragestellungen.



Prof. Dr. Dieter Prätzel-Wolters  
Institutsleiter

Kaiserslautern, im Juni 2001



# ON ADJOINT-BASED OPTIMIZATION OF A FREE SURFACE STOKES FLOW

SABINE REPKE, NICOLE MARHEINEKE, AND RENÉ PINNAU

ABSTRACT. This work deals with the optimal control of a free surface Stokes flow which responds to an applied outer pressure. Typical applications are fiber spinning or thin film manufacturing. We present and discuss two adjoint-based optimization approaches that differ in the treatment of the free boundary as either state or control variable. In both cases the free boundary is modeled as the graph of a function. The PDE-constrained optimization problems are numerically solved by the BFGS method, where the gradient of the reduced cost function is expressed in terms of adjoint variables. Numerical results for both strategies are finally compared with respect to accuracy and efficiency.

KEYWORDS. Film casting process; thin films; free surface Stokes flow; optimal control; Lagrange formalism

AMS-CLASSIFICATION. 49-xx, 35Q93, 76D55, 49Q10

## 1. INTRODUCTION

Free boundary value problems and their optimal control play a crucial role in many applications, e.g. in solidification, technical textile, or thin film manufacturing processes [1, 7, 19]. In film casting processes [2, 4, 14, 15, 16] a molten polymer is pressed through a nozzle, stretched, and cooled down by surrounding air flows to form a thin long film which is finally winded up by a spindle. The uniform thickness of the manufactured film is an important criterion for the quality of the resulting products. Hence, quality assessment requires the optimal control of the free surfaces.

Motivated by this process, for which asymptotic 2d-membrane models were derived and numerical simulations performed in [2, 4, 16], our goal is the adjoint-based optimization of a free surface flow. For simplicity, we restrict our considerations to a stationary isothermal Stokes flow whose shape responds to an ambient aerodynamic pressure acting on the free surfaces, see figure 2.1. Free boundaries make the optimization complex and costly, in particular the formulation of the necessary optimality conditions and the efficient numerical handling. Thus previous control approaches longing for a uniform thickness profile of the film close to the spindle [15] treated the boundaries as fixed, yielding a suboptimal optimization approach. In this paper, in contrast, we deal with the optimization of the full free surface and present two adjoint-based optimization approaches. They differ in the treatment of the free boundaries as either state or control variables, where the boundary is described by the graph of a function. This graph approach was already successfully applied to optimize a free boundary in a two-phase Stefan problem with outer wall temperature [7] and/or near-wall Lorentz forces [8] as control. A less restrictive approach for the Stefan problem, where the free boundary has been modeled by a level set function, was studied in [1].

Certainly, the resulting two PDE-constrained optimization problems differ in complexity. Considering the graph of the free surface as state variable yields a free boundary value Stokes flow as forward problem whose adjoints are given by Stokes flow on a fixed domain with an additional ordinary differential equation for the adjoint graph. Alternatively, we reformulate the free boundary value problem as a minimization problem where the kinematic boundary condition is incorporated in the cost function. Then, the graph of the free surface acts as a control variable and the forward problem simplifies to Stokes flow on a given domain. This approach is an approximation of the optimal control of a free surface flow, but the numerical handling is much easier due to fixed flow

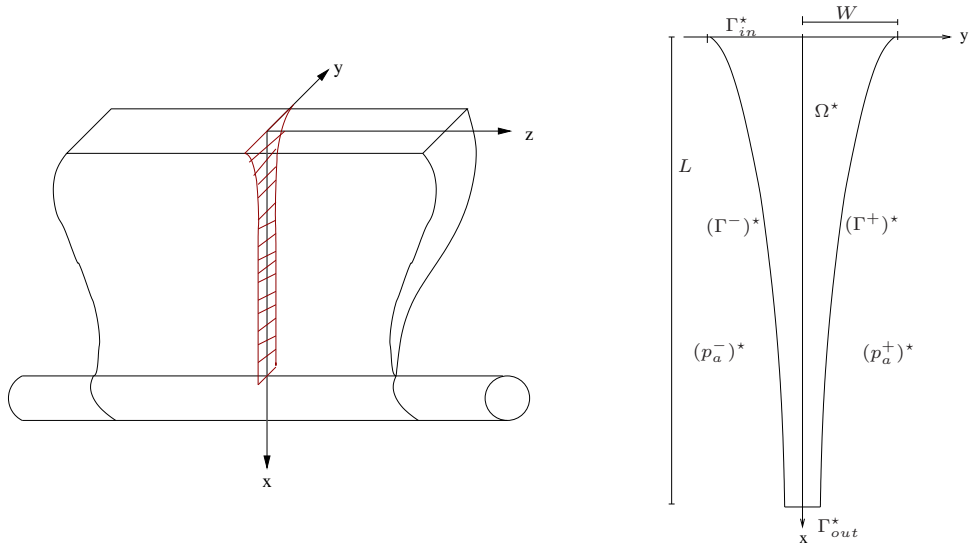

Fig. 2.1: Left: Schematic sketch of a spun film. The cross area yields the simplified flow domain for our considerations. Right: The simplified film domain with its geometrical quantities.

domains. The idea of shifting the additional boundary condition for the free boundary into the cost function was e.g. carried out for the optimization of a welding process in [19].

This paper is structured as follows. Starting with a mathematical model in section 2, we describe the thin film by a stationary incompressible two-dimensional Stokes flow whose free boundaries are represented by graphs. The shape design via an outer aerodynamic pressure is formulated in terms of two PDE-constrained optimization problems in section 3. Thereby, we distinguish between the free surface as state variable and as control variable. Using the Lagrangian formalism we derive the necessary optimality conditions. In section 4 we present the numerical treatment which is based on the BFGS method [9, 11]. Special attention is paid particularly to the numerical approaches for forward and backward problems in the optimization of the free boundary Stokes flow. Numerical results for both optimization problems are presented and discussed in section 5. Particularly, we compare the two optimization strategies with respect to accuracy and efficiency. Finally, a summary and outlook conclude the paper.

## 2. MODEL

In film casting processes molten polymer is pressed through a long narrow nozzle to form thin endless films. These are stretched and cooled down by surrounding air flows to be finally winded up by a spindle. In view of the complexity of the desired optimization we restrict ourselves to a simplified stationary scenario in this paper. Neglecting temperature dependencies a spun film of certain length is studied whose shape responds to an outer aerodynamic pressure acting on the free surfaces. We consider a slender highly viscous incompressible film that leaves vertically the spinning nozzle and falls straight down. Assuming the velocity profile at the inlet to be uniform with magnitude  $v_{in}$  and homogeneous in direction of the  $z$ -axis, allows the study of the film in terms of a stationary incompressible Stokes flow for velocity and pressure in a 2d domain  $\Omega^* \subset \mathbb{R}^2$  with boundary  $\partial\Omega^* = \Gamma_{in}^* \cup \Gamma_{out}^* \cup (\Gamma^+)^* \cup (\Gamma^-)^*$  as visualized in figure 2.1. Let  $W$  denote the nozzle's half width and  $L$  the length of the considered flow domain. The shape of the *a priori* unknown surfaces  $(\Gamma^\pm)^*$  is formed by the acting outer pressure  $(p_a^\pm)^*$  that is assumed to change over the film length.

Note that throughout this work we denote quantities for the right flow boundary with an index  $+$  and for the left boundary with  $-$  and summarize them with the abbreviation  $\pm$ . To keep the

expressions short we also summarize equations being valid on both boundaries with their respective quantities in the  $\pm$ -notation.

Making the free surface Stokes flow dimensionless with help of the film length  $L$  and magnitude of the inflow velocity  $v_{in}$  and introducing the typical pressure  $\mu v_{in}/L$  with kinematic flow viscosity  $\mu$ , we obtain the following system of model equations

$$\nabla \cdot \mathbf{v} = 0, \quad \nabla \cdot \mathbf{T} = \mathbf{0} \quad \text{in } \Omega(\psi^\pm), \quad (2.1a)$$

$$\mathbf{v} - \mathbf{v}_{in} = \mathbf{0} \quad \text{on } \Gamma_{in}, \quad (2.1b)$$

$$\mathbf{T} \cdot \mathbf{n} = \mathbf{0} \quad \text{on } \Gamma_{out}, \quad (2.1c)$$

$$(\mathbf{T} + p_a^\pm \mathbf{I}) \cdot \mathbf{n} = \mathbf{0} \quad \text{on } \Gamma^\pm, \quad (2.1d)$$

$$\mathbf{v} \cdot \mathbf{n} = 0 \quad \text{on } \Gamma^\pm, \quad (2.1e)$$

with the dimensionless flow geometry-associated quantities  $\Omega$ ,  $\Gamma_{in}$ ,  $\Gamma_{out}$ ,  $\Gamma^\pm$  and unit outer normal vector  $\mathbf{n}$ . Here,  $\mathbf{v} = (v_1, v_2)^T$  and  $p$  denote the unknown fluid velocity and pressure,  $\mathbf{T} = -p\mathbf{I} + (\nabla\mathbf{v} + \nabla\mathbf{v}^T)$  is the symmetric Newtonian stress tensor and  $\mathbf{I}$  the unit tensor. Since the flow geometry is an unknown of the problem, the incompressible Stokes equations for mass and momentum conservation are equipped not only with Dirichlet conditions with inflow  $\mathbf{v}_{in}$  on  $\Gamma_{in}$ , stress-free conditions on the outlet  $\Gamma_{out}$ , dynamic conditions balancing the outer aerodynamic pressure  $p_a^\pm$  acting on  $\Gamma^\pm$ , but also with an additional kinematic condition (2.1e) on  $\Gamma^\pm$ . We assume that the right and left flow boundaries  $\Gamma^\pm$  can be represented by graphs  $\psi^\pm : \mathbf{I} = (0, 1) \rightarrow \mathbb{R}$ , respectively. In view of film casting this assumption on the shape is certainly applicable, not much restrictive and a common approach see e.g. [2, 15, 16]. Then the flow domain is given by

$$\Omega(\psi^\pm) = \{(x, y) \in \mathbb{R}^2 : x \in \mathbf{I}, y \in [\psi^-(x), \psi^+(x)], \text{ with } \psi^\pm(0) = \pm w\}, \quad w = W/L,$$

with the boundaries  $\Gamma^\pm$  and their respective unit outer normal vectors  $\mathbf{n}^\pm$

$$\Gamma^\pm = \{(x, \psi^\pm(x)) : x \in \mathbf{I}\}, \quad \mathbf{n}^\pm = \frac{1}{\sqrt{1 + (\psi_x^\pm)^2}} (\mp \psi_x^\pm, \pm 1)^T, \quad (2.2)$$

where  $\psi_x^\pm$  denotes the derivative of the graphs. We define  $\Psi^\pm : \mathbf{I} \rightarrow \mathbb{R}^2$ ,  $\Psi^\pm(x) = (x, \psi^\pm(x))$ .

### 3. OPTIMIZATION

Our goal is the optimal control of the flow boundaries  $\Gamma^\pm$  using an applied outer aerodynamic pressure  $p_a^\pm$  as control variable. The introduction of the graph functions  $\psi^\pm$  ensures direct access to the free boundaries (2.2) in terms of optimization variables, analogously to [7, 8]. Consequently, the desired boundaries  $\Gamma_d^\pm$  are also described by graphs  $\psi_d^\pm$ . In this section we study two adjoint-based approaches for the free surface Stokes flow, that differ in the treatment of the graphs as either state or control variables. We state the two different minimization problems and, with help of the Lagrangian formalism, we derive the respective first-order necessary optimality conditions.

**3.1. PDE-constrained minimization problems.** In an optimal control problem, the optimal state  $\bar{y}$  and its associated optimal control  $\bar{u}$  are determined as minimizers of a suitable cost function  $J(y, u)$ , measuring the error between the actual and the desired system responses. The general form of such a minimization problem reads

$$\min_{(y, u) \in \mathcal{Y} \times \mathcal{U}} J(y, u), \quad (3.1a)$$

$$\text{subject to } e(y, u) = 0, \quad (3.1b)$$

where  $y$  and  $u$  are state and control variables, respectively. The space of the state  $\mathcal{Y}$  and of the admissible controls  $\mathcal{U}$  are assumed to be equipped with a Hilbert space structure. Besides the equality constraint  $e(y, u) = 0$  represents the equations of state.

*Graphs as state variable.* Treating the graphs as state variable [13], the state variable consists of fluid velocity  $\mathbf{v}$ , pressure  $p$  and graphs  $\psi^\pm$ , whereas the control is the ambient pressure  $p_a^\pm$ . To keep the expressions short we define  $y_1 := (\mathbf{v}, p, \psi^\pm)$  and  $u_1 := p_a^\pm$ . Then our first minimization problem reads

$$\left. \begin{aligned} \min J_1(\psi^\pm, p_a^\pm) &:= \frac{\alpha^\pm}{2} \int_0^1 (\psi^\pm - \psi_d^\pm)^2 dx + \frac{\beta^\pm}{2} \int_0^1 (\partial_x (\psi^\pm - \psi_d^\pm))^2 dx \\ &\quad + \frac{\gamma^\pm}{2} \int_0^1 (p_a^\pm)^2 dx \end{aligned} \right\} \quad (\text{P1})$$

subject to  $e_1(y_1, u_1) = 0$ , given by (2.1),

where the parameters  $\alpha^\pm, \beta^\pm, \gamma^\pm \geq 0$  weight the objective and control costs. For the control space we have  $\mathcal{U}_1 = \mathcal{L}^2(\mathbf{I})$ . The cost function  $J_1$  measures the deviation of the free boundaries from the desired ones. A penalty term thereby forces sufficient regularity of the graphs  $\psi^\pm$ , in particular we assume  $\psi^\pm \in \mathcal{H}^1(\mathbf{I})$ . Note, that here and throughout the paper, in the definitions of the cost functions, the  $\pm$ -abbreviation for an summand actually stands for two summands, one with the upper signs and one with the lower signs.

*Graphs as control variable.* Characteristic for free surface problems is the additional kinematic boundary condition for the free surface. Analogously to Volkov et al. [18, 19], we incorporate it now in the cost function such that the graphs become extra control variables in addition to the ambient pressure. This involves a Stokes system on a fixed domain as equality constraint. With the state variable  $y_2 := (\mathbf{v}, p)$  and the control  $u_2 := (\psi^\pm, p_a^\pm)$ , our second PDE-constrained minimization problem reads

$$\left. \begin{aligned} \min J_2(\mathbf{v}, \psi^\pm, p_a^\pm) &:= \frac{\alpha^\pm}{2} \int_0^1 (\psi^\pm - \psi_d^\pm)^2 dx + \frac{\beta^\pm}{2} \int_0^1 (\partial_x (\psi^\pm - \psi_d^\pm))^2 dx \\ &\quad + \frac{\gamma^\pm}{2} \int_0^1 (p_a^\pm)^2 dx + \frac{\delta^\pm}{2} \int_0^1 \left( (\mathbf{v} \circ \Psi^\pm) \cdot \begin{pmatrix} \mp \psi_x^\pm \\ \pm 1 \end{pmatrix} \right)^2 \frac{1}{\sqrt{1 + (\psi_x^\pm)^2}} dx \end{aligned} \right\} \quad (\text{P2})$$

subject to  $e_2(y_2, u_2) = 0$ , given by (2.1a)-(2.1d) on  $\Omega(\psi^\pm)$  for fixed  $\psi^\pm$ ,

with weights  $\alpha^\pm, \beta^\pm, \gamma^\pm, \delta^\pm \geq 0$ . Let  $\mathcal{H}_{0,0}^1(\mathbf{I}) := \{\phi \in \mathcal{H}^1(\mathbf{I}) : \phi(0) = 0\}$ , then the control space is  $\mathcal{U}_2 = \{\pm w + \mathcal{H}_{0,0}^1(\mathbf{I})\} \times \mathcal{L}^2(\mathbf{I})$ . The last term in  $J_2$ , representing (2.1e), results from the parameterization (2.2), i.e.

$$\int_{\Gamma^\pm} (\mathbf{v} \cdot \mathbf{n})^2 dS = \int_0^1 \left( (\mathbf{v} \circ \Psi^\pm) \cdot \begin{pmatrix} \mp \psi_x^\pm \\ \pm 1 \end{pmatrix} \frac{1}{\sqrt{1 + (\psi_x^\pm)^2}} \right)^2 \sqrt{1 + (\psi_x^\pm)^2} dx.$$

**3.2. Lagrange formalism.** Before applying the Lagrange techniques to our optimal control problems (P1) and (P2), we briefly recall the Lagrange formalism [6, 17] for the general PDE-constrained optimization problem (3.1). Assume that the equality constraint  $e : \mathcal{Y} \times \mathcal{U} \rightarrow \mathcal{Z}$  with suitable space  $\mathcal{Z}$  and the cost function  $J : \mathcal{Y} \times \mathcal{U} \rightarrow \mathbb{R}$  are continuously Fréchet differentiable. The Lagrange function  $L : \mathcal{Y} \times \mathcal{U} \times \mathcal{Z}^* \rightarrow \mathbb{R}$ , associated to (3.1), is defined by

$$L(y, u, \hat{y}) = J(y, u) + \langle \hat{y}, e(y, u) \rangle_{\mathcal{Z}^*, \mathcal{Z}}$$

with Lagrange multiplier  $\hat{y} \in \mathcal{Z}^*$  and appropriate duality pairing  $\langle \cdot, \cdot \rangle_{\mathcal{Z}^*, \mathcal{Z}}$ . According to the Lagrange multiplier theorem, the variations of the Lagrangian with respect to its arguments vanish at a critical point  $(\bar{y}, \bar{u}, \bar{\hat{y}})$ , which yields the first order optimality system, or Karush-Kuhn-Tucker (KKT) system,

$$\partial_y L(\bar{y}, \bar{u}, \bar{\hat{y}})[\tilde{y}] = 0, \quad \partial_{\bar{y}} L(\bar{y}, \bar{u}, \bar{\hat{y}})[\tilde{\hat{y}}] = 0, \quad \partial_u L(\bar{y}, \bar{u}, \bar{\hat{y}})[\tilde{u}] = 0,$$

for all feasible directions  $\tilde{y}, \tilde{\hat{y}}, \tilde{u}$ . In particular, the variation wrt. the state variables gives the adjoint equations, wrt. the Lagrange multiplier the equality constraint, and wrt. the control the optimality condition, i.e. the gradient of the reduced cost function  $\tilde{J}(u) = J(y(u), u)$ . This presupposes that



each control  $u$  admits a unique solution  $y$ . In the following we formally apply the Lagrange approach to (P1) and (P2). For a detailed derivation of the optimality conditions we refer to [12].

*Lagrange approach for (P1).* The adjoint equations for (P1) are

$$\nabla \cdot \hat{\mathbf{v}} = 0, \quad \nabla \cdot \hat{\mathbf{T}} = \mathbf{0} \quad \text{in } \Omega(\psi^\pm), \quad (3.2a)$$

$$\hat{\mathbf{v}} = \mathbf{0} \quad \text{on } \Gamma_{in}, \quad (3.2b)$$

$$\hat{\mathbf{T}} \cdot \mathbf{n} = \mathbf{0} \quad \text{on } \Gamma_{out}, \quad (3.2c)$$

$$\hat{\mathbf{T}} \cdot \mathbf{n} = \hat{\psi}^\pm \mathbf{n} \quad \text{on } \Gamma^\pm, \quad (3.2d)$$

$$\frac{1}{v_1 \circ \Psi^\pm} \left( \alpha^\pm (\psi^\pm - \psi_d^\pm) - \beta^\pm \partial_{xx} (\psi^\pm - \psi_d^\pm) \mp \partial_x p_a^\pm (\hat{v}_1 \circ \Psi^\pm) \right. \\ \left. \mp \left( \partial_1 \hat{\mathbf{v}} \circ \Psi^\pm \cdot (\mathbf{T} \circ \Psi^\pm + p_a^\pm \mathbf{I}) \right)_1 \right) = \hat{\psi}_x^\pm \quad x \in \text{I}, \quad (3.2e)$$

$$\frac{1}{v_1 \circ \Psi^\pm} \left( \left( \hat{\mathbf{v}} \circ \Psi^\pm \cdot (\mathbf{T} \circ \Psi^\pm + p_a^\pm \mathbf{I}) \right)_1 \pm \beta^\pm \partial_x (\psi^\pm - \psi_d^\pm) \right) = \hat{\psi}^\pm \quad x = 1, \quad (3.2f)$$

It is a Stokes system (3.2a)-(3.2d) for the adjoint fluid velocity  $\hat{\mathbf{v}} = (\hat{v}_1, \hat{v}_2)^T$  and pressure  $\hat{p}$  with adjoint stress tensor  $\hat{\mathbf{T}} = -\hat{p}\mathbf{I} + (\nabla \hat{\mathbf{v}} + \nabla \hat{\mathbf{v}}^T)$  on the *a priori* known domain that is given by the solutions  $\psi^\pm$  of (2.1). The system is coupled to a reverse value problem of an ordinary differential equation (ODE) of first order (3.2e)-(3.2f) for the adjoint graph functions  $\hat{\psi}^\pm$  which enter in the dynamic boundary conditions on  $\Gamma^\pm$  (3.2d). Note that  $\mathbf{v}, p, \psi^\pm$  are the solutions of (2.1). Due to the set-up of the problem the velocity component in  $x$ -direction satisfies  $v_1 \neq 0$ , cf. figure 2.1. Be aware that the subscript  $_1$  at a vector denotes its first component and  $\partial_i$  abbreviates the partial derivative with respect to the  $i$ th component,  $i = 1, 2$ .

The gradient of the reduced cost function is

$$\nabla \tilde{J}_1(p_a^\pm) = \gamma^\pm p_a^\pm - \mathbf{n}^\pm \cdot (\hat{\mathbf{v}} \circ \Psi^\pm) \sqrt{1 + (\psi_x^\pm)^2}, \quad x \in \text{I}.$$

*Lagrange approach for (P2).* The adjoint equations for (P2) are

$$\nabla \cdot \hat{\mathbf{v}} = 0, \quad \nabla \cdot \hat{\mathbf{T}} = \mathbf{0} \quad \text{in } \Omega(\psi^\pm),$$

$$\hat{\mathbf{v}} = \mathbf{0} \quad \text{on } \Gamma_{in},$$

$$\hat{\mathbf{T}} \cdot \mathbf{n} = \mathbf{0} \quad \text{on } \Gamma_{out},$$

$$\hat{\mathbf{T}} \cdot \mathbf{n} = \delta^\pm \mathbf{n} (\mathbf{v} \cdot \mathbf{n}) \quad \text{on } \Gamma^\pm.$$

Again, we have a Stokes system for the adjoint velocity  $\hat{\mathbf{v}}$  and pressure  $\hat{p}$  on the same domain as its forward problem, i.e.  $\psi^\pm$  is given.

Since  $\partial_{\psi^\pm} \tilde{J}_2 \in \mathcal{H}^{-1}(\text{I})$

$$\left\langle \partial_{\psi^\pm} \tilde{J}_2, \tilde{\psi}^\pm \right\rangle_{\mathcal{H}^{-1}(\text{I}), \mathcal{H}^1(\text{I})} = \int_0^1 \left( \tilde{\psi}_x^\pm a^\pm + \tilde{\psi}^\pm b^\pm \right) dx \pm \tilde{\psi}^\pm p_a^\pm (\hat{v}_1 \circ \Psi^\pm)|_{x=1},$$

with

$$a^\pm = \beta^\pm \partial_x (\psi^\pm - \psi_d^\pm) - \frac{\delta^\pm}{2} \left( (\mathbf{v} \circ \Psi^\pm) \cdot \mathbf{n} \right)^2 \frac{\psi_x^\pm}{\sqrt{1 + (\psi_x^\pm)^2}} \mp \delta^\pm (v_1 \circ \Psi^\pm) \left( (\mathbf{v} \circ \Psi^\pm) \cdot \mathbf{n} \right),$$

$$b^\pm = \alpha^\pm (\psi^\pm - \psi_d^\pm) \pm \delta^\pm \left( (\mathbf{v} \circ \Psi^\pm) \cdot \mathbf{n} \right) \left( -\psi_x^\pm \partial_2 v_1 \circ \Psi^\pm + \partial_2 v_2 \circ \Psi^\pm \right) \\ \mp \partial_x p_a^\pm (\hat{v}_1 \circ \Psi^\pm) \mp \left( \partial_1 \hat{\mathbf{v}} \circ \Psi^\pm \cdot (\mathbf{T} \circ \Psi^\pm + p_a^\pm \mathbf{I}) \right)_1,$$

**Algorithm 1** BGFS Method to Solve a Minimization Problem

---

**Input:** initial control  $u^{(0)}$   
**Output:** optimized control  $\bar{u}$  and corresponding optimal state  $\bar{y}$   
Solve forward and backward problem (use  $u^{(0)}$  to compute  $y^{(0)}, \hat{y}^{(0)}$ )  
Evaluate  $\nabla \tilde{J}(u^{(0)})$   
 $k \leftarrow 0$   
Set restart parameter  $r$   
 $B \leftarrow \mathbf{I}$   
**while**  $\|\nabla \tilde{J}(u^{(k)})\| / \|\nabla \tilde{J}(u^{(0)})\| > tol$  **do**  
  Compute search direction:  $d^{(k)} \leftarrow -B^{-1} \nabla \tilde{J}(u^{(k)})$   
  **if**  $d^{(k)}$  is not a search direction or  $k \bmod r = 0$  **then**  
     $B \leftarrow \mathbf{I}$   
     $d^{(k)} \leftarrow -\nabla \tilde{J}(u^{(k)})$   
  **end if**  
  Compute step length  $\sigma^{(k)}$  fulfilling Armijo rule (4.1)  
  Update the control:  $u^{(k+1)} \leftarrow u^{(k)} + \sigma^{(k)} d^{(k)}$   
  Solve forward and backward problem (use  $u^{(k+1)}$  to compute  $y^{(k+1)}, \hat{y}^{(k+1)}$ )  
  Evaluate  $\nabla \tilde{J}(u^{(k+1)})$   
  Update Hessian  $B$ : set  $s \leftarrow \sigma^{(k)} d^{(k)}$ ,  $z \leftarrow \nabla \tilde{J}(u^{(k+1)}) - \nabla \tilde{J}(u^{(k)})$   
    
$$B \leftarrow B + \frac{z z^T}{z^T s} - \frac{(Bs)(Bs)^T}{s^T Bs}$$
  
   $k \leftarrow k + 1$   
**end while**  
 $\bar{u} \leftarrow u^{(k)}$ ,  $\bar{y} \leftarrow y^{(k)}$

---

we determine the Riesz representative of the gradient  $g^\pm \in \mathcal{H}^1(\mathbf{I})$  as the weak solution of

$$\begin{aligned} -\eta^\pm \partial_{xx} g^\pm + g^\pm &= -\partial_x a^\pm + b^\pm && \text{for } x \in \mathbf{I}, \\ g^\pm &= 0 && \text{for } x = 0, \\ \partial_x g^\pm &= \frac{a^\pm \pm p_a^\pm (\hat{v}_1 \circ \Psi^\pm)}{\eta^\pm} && \text{for } x = 1. \end{aligned}$$

for an appropriately chosen smoothing parameter  $\eta^\pm > 0$ . Then the gradient of the reduced cost function is

$$\nabla \tilde{J}_2(\psi^\pm, p_a^\pm) = \left( \begin{array}{c} g^\pm \\ \gamma^\pm p_a^\pm - \mathbf{n}^\pm \cdot (\hat{\mathbf{v}} \circ \Psi^\pm) \sqrt{1 + (\psi_x^\pm)^2} \end{array} \right), \quad x \in \mathbf{I}.$$

Note  $\|\nabla \tilde{J}_2\|_{\mathcal{U}_2}^2 := \|g^\pm\|_{\mathcal{L}^2(\mathbf{I})}^2 + \eta^\pm \|g_x^\pm\|_{\mathcal{L}^2(\mathbf{I})}^2 + \|\partial_{p_a^\pm} \tilde{J}_2\|_{\mathcal{L}^2(\mathbf{I})}^2$ .

#### 4. NUMERICAL APPROACH

Both optimization problems, (P1) and (P2), are numerically solved using the Broyden-Fletcher-Goldfarb-Shanno (BFGS) method [9, 11] that is briefly presented in the following. The gradients of the reduced cost functions are expressed in terms of the respective adjoint variables. For generality we suppress the indices specifying the single problems. Moreover, we pay special attention to the free surface problem of (P1) whose numerical treatment we discuss in detail.

**4.1. BFGS method.** To find a minimizer  $\bar{u}$  of the reduced cost function  $\tilde{J}$  we apply the BFGS method. It is a Quasi-Newton method where the Hessian is approximated with help of gradient information, see algorithm 1 and [9, 11]. In each iteration  $k$  of the optimization procedure a search direction  $d^{(k)} = -B^{-1} \nabla \tilde{J}(u^{(k)})$  is determined by help of an approximated Hessian  $B$ . Then the control is computed as

$$u^{(k+1)} = u^{(k)} + \sigma^{(k)} d^{(k)},$$

**Algorithm 2** Algorithm for the Forward System (2.1)

---

**Input:**  $p_a^\pm$   
**Output:**  $\mathbf{v}, p, \psi^\pm$   
 $i \leftarrow 0$   
 Initial boundary  $\psi^{\pm(0)} \leftarrow \pm w$   
**FEM-Solve** for system (2.1a)-(2.1d): use  $\psi^{\pm(0)}$  to compute  $\mathbf{v}^{(0)}, p^{(0)}$   
**while**  $\|\mathbf{v}^{(i)} \cdot \mathbf{n}^{(i)}\|_{\mathcal{L}^2(\Gamma^\pm)} > tol_1$  **do**  
      $i \leftarrow i + 1$   
     **ODE-Solve:** compute  $\psi^{\pm(i)}$  via (4.3)  
     **FEM-Solve** for system (2.1a)-(2.1d): use  $\psi^{\pm(i)}$  to compute  $\mathbf{v}^{(i)}, p^{(i)}$   
     **while**  $\|\mathbf{v}^{(i)} \cdot \mathbf{n}^{(i)}\|_{\mathcal{L}^2(\Gamma^\pm)} > \|\mathbf{v}^{(i-1)} \cdot \mathbf{n}^{(i-1)}\|_{\mathcal{L}^2(\Gamma^\pm)}$  **do**  
          $\psi^{\pm(i)} \leftarrow (\psi^{\pm(i)} + \psi^{\pm(i-1)})/2$   
         **FEM-Solve** for system (2.1a)-(2.1d): use  $\psi^{\pm(i)}$  to compute  $\mathbf{v}^{(i)}, p^{(i)}$   
     **end while**  
**end while**  
 $\mathbf{v} \leftarrow \mathbf{v}^{(i)}, p \leftarrow p^{(i)}, \psi^\pm \leftarrow \psi^{\pm(i)}$

---

with appropriately chosen step length  $\sigma^{(k)} > 0$ . The step length needs to ensure a substantial reduction of the objective function  $\tilde{J}$ . Applying Armijo's rule we choose  $\sigma^{(k)} = \kappa^m$ , where  $\kappa \in (0, 1)$  and  $m \geq 0$  is the smallest nonnegative integer such that  $\sigma^{(k)}$  guarantees sufficient decrease of  $\tilde{J}$ , i.e.

$$\tilde{J}(u^{(k)} + \sigma^{(k)} d^{(k)}) \leq \tilde{J}(u^{(k)}) + \epsilon \sigma^{(k)} \langle \nabla \tilde{J}(u^{(k)}), d^{(k)} \rangle, \quad (4.1)$$

with some constant  $\epsilon \in (0, 1)$ . The approximation of the Hessian  $B$  is updated by

$$B = B + \frac{z z^T}{z^T s} - \frac{(Bs)(Bs)^T}{s^T B s},$$

with  $s := \sigma^{(k)} d^{(k)}$  and  $z := \nabla \tilde{J}(u^{(k+1)}) - \nabla \tilde{J}(u^{(k)})$ . Due to reasons of convergence a restart functionality is incorporated in algorithm 1.

**4.2. Algorithms for the free boundary problem (P1).** The main challenge of the numerical handling of problem (P1) is the *a priori* unknown flow domain  $\Omega(\psi^\pm)$  of the forward problem. The adjoint system of problem (P1) consists of a Stokes system coupled to a first order ODE for the adjoint graphs. We suggest to use, for both problems, a numerical approach based on fixed point iterations, since we couple existing software routines.

*Forward problem.* To find, for a given ambient pressure  $p_a^\pm$ , the graph functions  $\psi^\pm$  as well as velocity and pressure fields  $\mathbf{v}, p$  we perform the computation of (2.1) via a fixed point iteration consisting of two parts. As a result of the graph approach, we are able to reformulate the kinematic boundary condition (2.1e) in terms of a first order ODE

$$\psi_x^\pm(x) = \frac{v_2}{v_1}(x, \psi^\pm(x)) \quad \text{for } x \in \mathbf{I}, \quad \psi^\pm(0) = \pm w. \quad (4.2)$$

The initial condition follows from the geometrical set-up. On the domain given by  $\psi^\pm$  we determine the flow quantities  $\mathbf{v}, p$  from the remaining system. We go on with the iteration  $i$  until the  $\mathcal{L}^2$ -error of the kinematic boundary condition is smaller than a tolerance. Note that for the numerical evaluation of (4.2), we use the quantities of the last fixed point iteration step, i.e.  $\mathbf{v}^{(i-1)}$  on  $\psi^{\pm(i-1)}$ , to approximate the new graph  $\psi^{\pm(i)}$ . Explicit integration yields

$$\psi^{\pm(i)}(x) = \pm w + \int_0^x \frac{v_2^{(i-1)}}{v_1^{(i-1)}}(\tilde{x}, \psi^{\pm(i-1)}(\tilde{x})) d\tilde{x}. \quad (4.3)$$

Due to this simplification we might apply a relaxation, determining the new graph as linear combination of the old one and the one of (4.3), see algorithm 2. The iteration is initialized with  $\psi^{\pm(0)} \equiv \pm w$ .

**Algorithm 3** Algorithm for the Adjoint System (3.2)

---

**Input:**  $p_a^\pm$  and solutions of the forward problem for  $p_a^\pm$ :  $\mathbf{v}, p, \psi^\pm$   
**Output:**  $\hat{\mathbf{v}}, \hat{p}, \hat{\psi}^\pm$   
 $i \leftarrow 0$   
Initial adjoint graph function  $\hat{\psi}^{\pm(0)}(x) \leftarrow 0$   
**FEM-Solve** for equations (3.2a)-(3.2d): use  $\hat{\psi}^{\pm(0)}$  to compute  $\hat{\mathbf{v}}^{(0)}, \hat{p}^{(0)}$   
Evaluate  $\ell^{\pm(0)}$  (4.4)  
**while**  $\|\ell^{\pm(i)} - \hat{\psi}_x^{\pm(i)}\|_{\mathcal{L}^2(\Gamma)} > tol_2$  **do**  
     $i \leftarrow i + 1$   
    **ODE-Solve:** compute  $\hat{\psi}^{\pm(i)}$  via (4.5)  
    **FEM-Solve** for equations (3.2a)-(3.2d): use  $\hat{\psi}^{\pm(i)}$  to compute  $\hat{\mathbf{v}}^{(i)}, \hat{p}^{(i)}$   
    Evaluate  $\ell^{\pm(i)}$   
**end while**  
 $\hat{\mathbf{v}} \leftarrow \hat{\mathbf{v}}^{(i)}, \hat{p} \leftarrow \hat{p}^{(i)}, \hat{\psi}^\pm \leftarrow \hat{\psi}^{\pm(i)}$

---

*Adjoint problem.* For the adjoint system the domain is known. However, we also deal with a coupled system consisting of Stokes equations and a first order ODE for the graphs  $\hat{\psi}^\pm$ . Analogously to algorithm 2, we apply a fixed point method and solve (3.2e)-(3.2f) and (3.2a)-(3.2d) iterative-wise. In this case the explicit integration of the ODE is no simplification, since the left hand side  $\ell^\pm$  of the ODE does not depend on  $\hat{\psi}^\pm$ ,

$$\ell^{\pm(i)} := \frac{\alpha^\pm (\psi^\pm - \psi_d^\pm) - \beta^\pm \partial_{xx} (\psi^\pm - \psi_d^\pm) \mp (\partial_x p_a^\pm) \hat{v}_1^{(i)} \circ \Psi^\pm \mp (\partial_1 \hat{\mathbf{v}}^{(i)} \cdot (\mathbf{T} + p_a^\pm \mathbf{I}) \circ \Psi^\pm)_1}{v_1 \circ \Psi^\pm}. \quad (4.4)$$

Thus, the adjoint graph function in the  $i$ th iteration is

$$\hat{\psi}^{\pm(i)}(x) = \frac{(\hat{\mathbf{v}}^{(i-1)} \cdot (\mathbf{T} + p_a^\pm \mathbf{I}) \circ \Psi^\pm)_1 \pm \beta^\pm \partial_x (\psi^\pm - \psi_d^\pm)}{v_1 \circ \Psi^\pm} \Bigg|_{x=1} - \int_x^1 \ell^{\pm(i-1)}(x) dx. \quad (4.5)$$

As termination criterion of the iteration we use the validity of the ODE, i.e. the  $\mathcal{L}^2$ -error between graph derivative and left hand side has to satisfy  $\|\ell^{\pm(i)} - \hat{\psi}_x^{\pm(i)}\|_{\mathcal{L}^2(\Gamma)} \leq tol_2$ . A detailed description is given in algorithm 3.

**Remark 1.** *Within the optimization procedure we accelerate the forward solve (algorithm 2) by using the solution  $\psi^\pm$  of the previous forward solve as an initial guess for the boundary graph. Analogously we accelerate the backward solve (algorithm 3) by choosing the solution  $\hat{\psi}^\pm$  of the previous backward solve as an initial guess.*

**Remark 2.** *For both optimization problems, the BFGS approach including the stated algorithms for solving the forward and adjoint systems and the computation of the gradients have been implemented in the software **Freefem++**\*, a free software for numerically solving PDEs by the Finite Element Method (FEM). Automatic mesh generation, mesh adaption, mesh movement, several triangular finite elements, as well as a large variety of solvers are already included [5]. The flow domain  $\Omega(\psi^\pm)$  is discretized into a Delaunay mesh of triangles by **Freefem++**. For the basis function for the pressure/adjoint pressure and velocity/adjoint velocity we choose **P1** and **P1-bubble** finite elements, cf. [3, 5] for technical details.*

## 5. NUMERICAL RESULTS AND DISCUSSION

In this section we discuss the numerical results for both optimization problems (P1) and (P2), focusing on the accuracy and efficiency of the strategies and studying the impact of the weighting

---

\*Software by Laboratoire Jaques-Louis Lions, Université Pierre et Marie Curie, Paris, France. Authors: F. Hecht, O. Pironneau, A. Le Hyaric, and K. Ohtsuka. [www.freefem.org/ff++](http://www.freefem.org/ff++)

| maximal discretization<br>width $h_{\max}$ | $\ \bar{p}_a\ _{\mathcal{L}^2(\Gamma)}$ | $\ \bar{\psi}\ _{\mathcal{L}^2(\Gamma)}$ | # of Armijo<br>steps ( $\emptyset$ ) | # of BFGS<br>iterations |
|--|---|--|--------------------------------------|-------------------------|
| (P1):                                      |   |  |                                      |                         |
| 0.05                                       | 2.629                                   | 0.4312                                   | 1.3                                  | 7                       |
| 0.025                                      | 2.568                                   | 0.4314                                   | 1.2                                  | 6                       |
| 0.0125                                     | 2.566                                   | 0.4314                                   | 1.3                                  | 5                       |
| 0.00625                                    | 2.568                                   | 0.4315                                   | 1.0                                  | 5                       |
| (P2):                                      |   |  |                                      |                         |
| 0.05                                       | 5.68                                    | 0.434                                    | 1.2                                  | 11                      |
| 0.025                                      | 5.62                                    | 0.435                                    | 1.2                                  | 10                      |
| 0.0125                                     | 5.58                                    | 0.435                                    | 1.2                                  | 10                      |
| 0.00625                                    | 5.56                                    | 0.435                                    | 1.2                                  | 10                      |

Table 5.1: Grid study: (P1) top and (P2) bottom. Dependence of optimal solutions, mean number of Armijo steps and number of BFGS iterations on the grid spacing.

parameters in the cost functions. We investigate different desired graphs  $\psi_d^\pm$  and varying parameters  $\alpha^\pm, \beta^\pm, \gamma^\pm, \delta^\pm$  and furthermore perform a study of the discretization.

Hence, all numerical simulations presented in this paper are performed for fixed processing conditions  $w = 0.5$  and  $\mathbf{v}_{in} = (1, 0)^\top$ . The desired boundaries are considered to be symmetrically shaped, i.e.  $\psi_d^+ = -\psi_d^- =: \psi_d$  which results in axis-symmetric optimization problems, cf. figure 2.1. Thus, we deal with the representative half problems and omit the  $\pm$ -notation. In accordance to the maximal discretization length  $h_{\max}$  for the flow domain, we set the tolerances to be  $tol_1 = h_{\max}$  and  $tol_2 = h_{\max}^3$  in algorithms 2 and 3 for (P1). The computation of the  $\mathcal{H}^1$ -gradient  $g$  for (P2) involves a smoothing parameter  $\eta$ . It turns out to be reasonable to choose  $\eta$  in the same order of magnitude as  $\alpha$ . In the BFGS method (algorithm 1) we use  $r = 5$  as restart parameter and  $\epsilon = 10^{-4}$  for the step length computation (4.1), cf. [9, 11].

Both optimization strategies turn out to be independent of the chosen discretization, as desired. For this purpose we investigate the optimal solutions  $(\bar{\psi}, \bar{p}_a)$ , the number of BFGS iterations and the mean number of interior Armijo steps with respect to various grid spacing for different settings. Table 5.1 exemplarily summarizes the results for  $h_{\max} = 0.1/2^i$ ,  $i = 1, \dots, 4$ , considering the desired boundary  $\psi_d(x) = 0.5 \cos x$ . The termination tolerance in the BFGS algorithm is  $tol = 10^{-2}$  and the weighting parameters in the cost functions are  $(\alpha, \beta) = (1000, 0)$  as well as  $\gamma = 0.1$  and  $(\gamma, \delta) = (0.01, 200)$  in (P1) and (P2), respectively. In the following we use  $h_{\max} = 0.025$ .

Obviously, the different choice of  $\gamma$  yields different pressure values in (P1) and (P2), cf. table 5.1. To provide the comparability of the two strategies with regard to accuracy and computational effort we consider the same weights  $(\alpha, \beta, \gamma)$ . The penalty parameter  $\delta$  of (P2) is chosen in such a way that the kinematic boundary condition is satisfied within the same tolerances as in algorithm 2, i.e.  $\|\bar{\mathbf{v}} \cdot \mathbf{n}\| \leq tol_1$ . Due to the differing gradients this requires different termination tolerances in the BFGS algorithm, in particular we have here  $tol = 10^{-3}$  for (P1) and  $tol = 10^{-2}$  for (P2). Figures 5.2 and 5.3 show the optimization results for two desired boundaries, a cosine-shaped  $\psi_d(x) = 0.5 \cos x$  and a linear-shaped graph  $\psi_d(x) = 0.5 - 0.2x$ . In particular, the optimal graph  $\bar{\psi}$ , the associated outer pressure  $\bar{p}_a$ , the evolution of the relative cost functions and of the gradients are visualized for varying regularizations  $\gamma \in \{10^{-1}, 10^{-2}, 10^{-3}\}$  and  $(\alpha, \beta) = (10^3, 10^{-1})$  fixed. Here,  $\delta \in (100, 200)$  ensures a comparable approximation quality of the kinematic boundary condition in both approaches. We see qualitatively similar results for (P1) and (P2). But for (P2) the deviation of the optimized graph from the desired one is larger and the ambient pressure smaller than for (P1). However, we observe that the computed solution of (P1) also satisfies (P2) within the chosen tolerances. Inserting instead the solution of (P2) as initial guess, the BFGS method for (P1) converges to its optimal results that are visualized.

(a) Cosine-shaped desired boundary  $\psi_d = 0.5 \cos x$ (b) Linear-shaped desired boundary  $\psi_d = 0.5 - 0.2x$ 

Fig. 5.2: Optimization results for (P1) with (a) cosine-shaped  $\psi_d$ , (b) linear-shaped  $\psi_d$ :  $\bar{\psi}$  (top left),  $\bar{p}_a$  (top right), evolution of the relative cost function (bottom left) and of the relative gradients (bottom right) for varying regularizations  $\alpha/\gamma \in \{10^4, 10^5, 10^6\}$  plotted in (red, green, blue).

(a) Cosine-shaped desired boundary  $\psi_d = 0.5 \cos x$ (b) Linear-shaped desired boundary  $\psi_d = 0.5 - 0.2x$ 

Fig. 5.3: Optimization results for (P2) with (a) cosine-shaped  $\psi_d$ , (b) linear-shaped  $\psi_d$ :  $\bar{\psi}$  (top left),  $\bar{p}_a$  (top right), evolution of the relative cost function (bottom left) and of the relative gradients (bottom right) for varying regularizations  $\alpha/\gamma \in \{10^4, 10^5, 10^6\}$  plotted in (red, green, blue).

| Setting<br>$\alpha/\gamma$ | # of BFGS<br>iterations | # of Armijo<br>steps ( $\emptyset$ ) | # FWD Stokes<br>solves ( $\emptyset$ ) | # BWD Stokes<br>solves ( $\emptyset$ ) | CPU-time |
|----------------------------|-------------------------|--------------------------------------|--|--|----------|
| (P1):                      |                         |                                      |  |  |          |
| $10^4$                     | 12                      | 3.5                                  | 9.3                                    | 4.1                                    | 272.3    |
| $10^5$                     | 14                      | 3.1                                  | 8.3                                    | 6.3                                    | 329.8    |
| $10^6$                     | 32                      | 1.1                                  | 4.5                                    | 5.0                                    | 483.2    |
| (P2):                      |                         |                                      |  |  |          |
| $10^4$                     | 16                      | 2.0                                  | 2.0                                    | 1.0                                    | 64.6     |
| $10^5$                     | 11                      | 3.6                                  | 3.6                                    | 1.0                                    | 78.9     |
| $10^6$                     | 22                      | 2.0                                  | 2.0                                    | 1.0                                    | 115.4    |

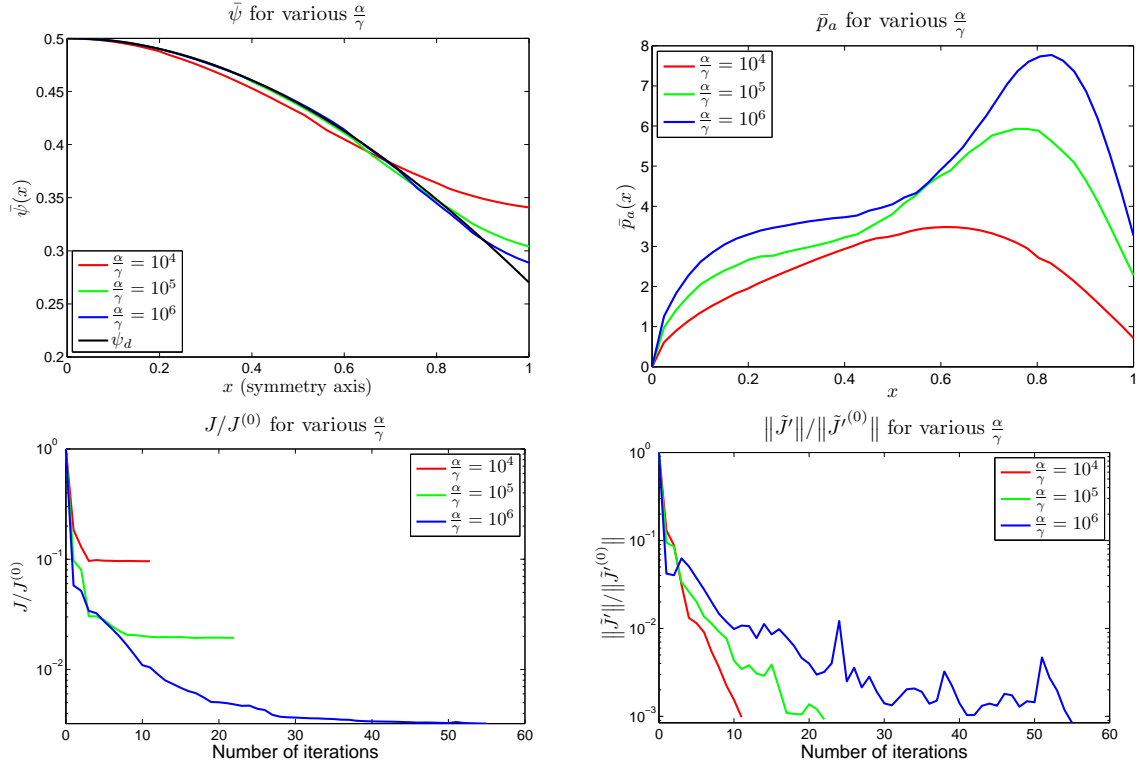
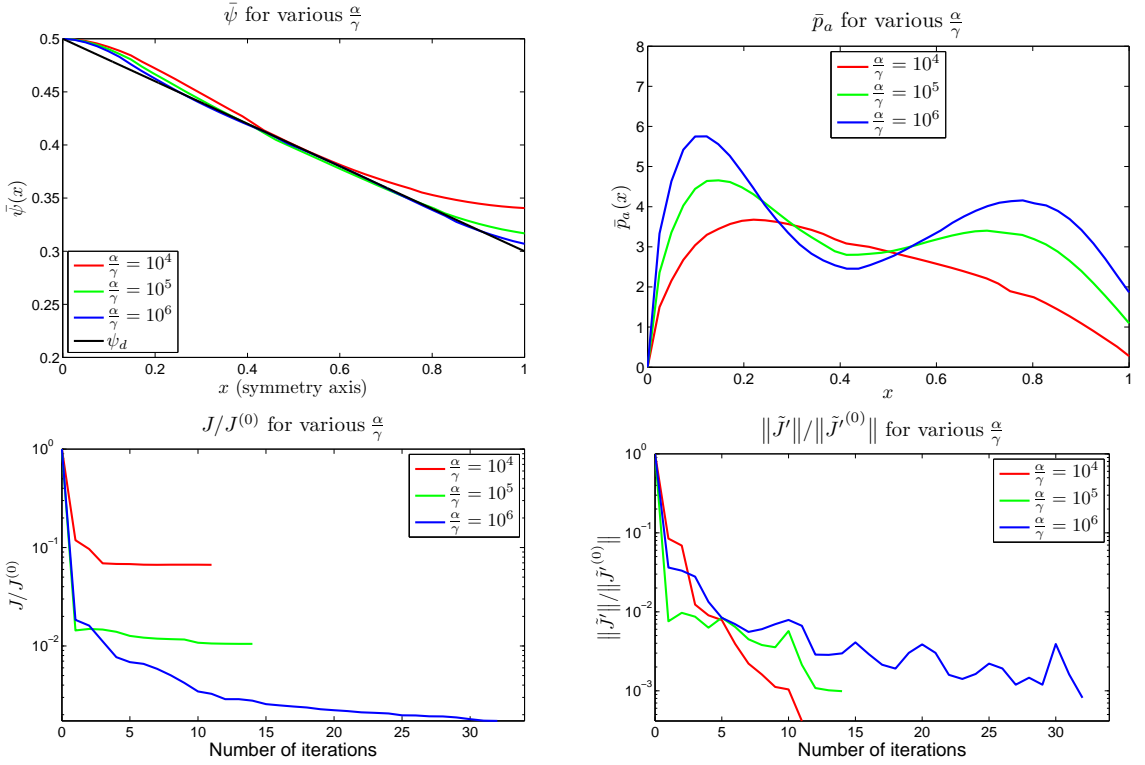
Table 5.2: Comparison wrt. efficiency: (P1) top and (P2) bottom. Total number of BFGS iterations, mean number of Armijo steps, forward and backward Stokes solves needed per BFGS iteration, and CPU-time for different regularizations.

Hence, (P2) is more robust to variations of the control  $p_a$ . This is not surprising since the kinematic boundary condition is incorporated and satisfied in terms of a penalty term in the cost function  $J_2$ . The peaks in the evolution of the relative gradients arise from the restarts within the BFGS algorithm.

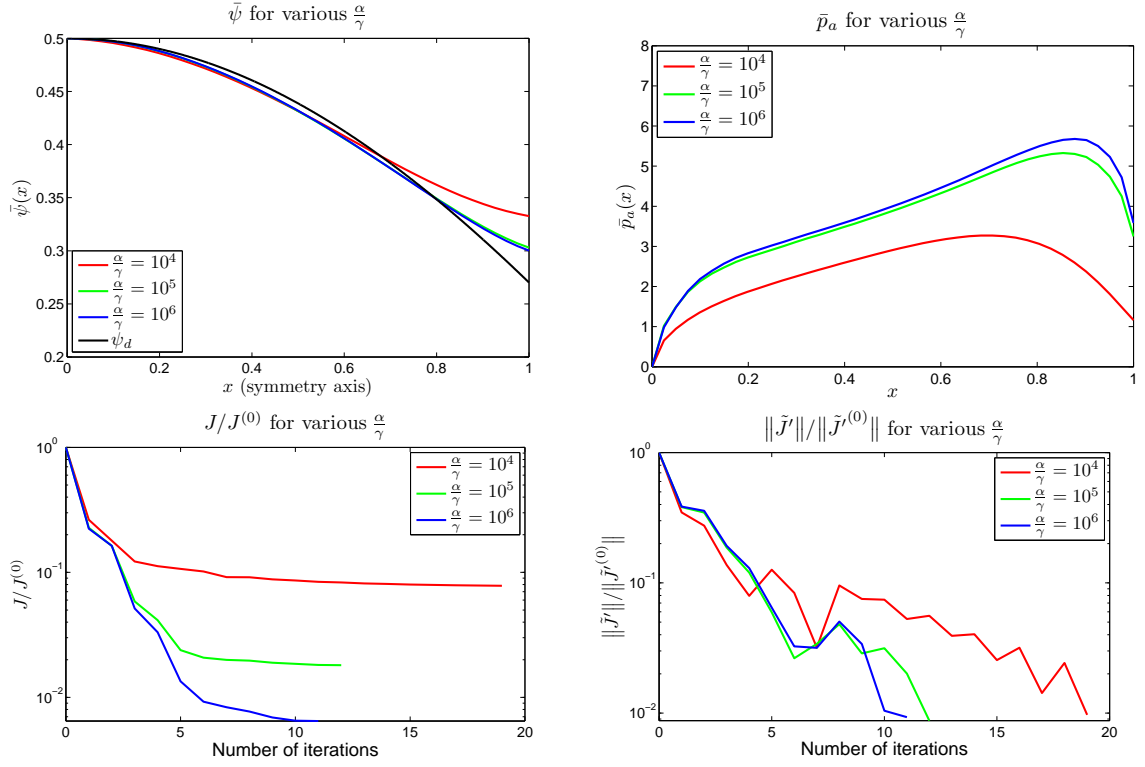
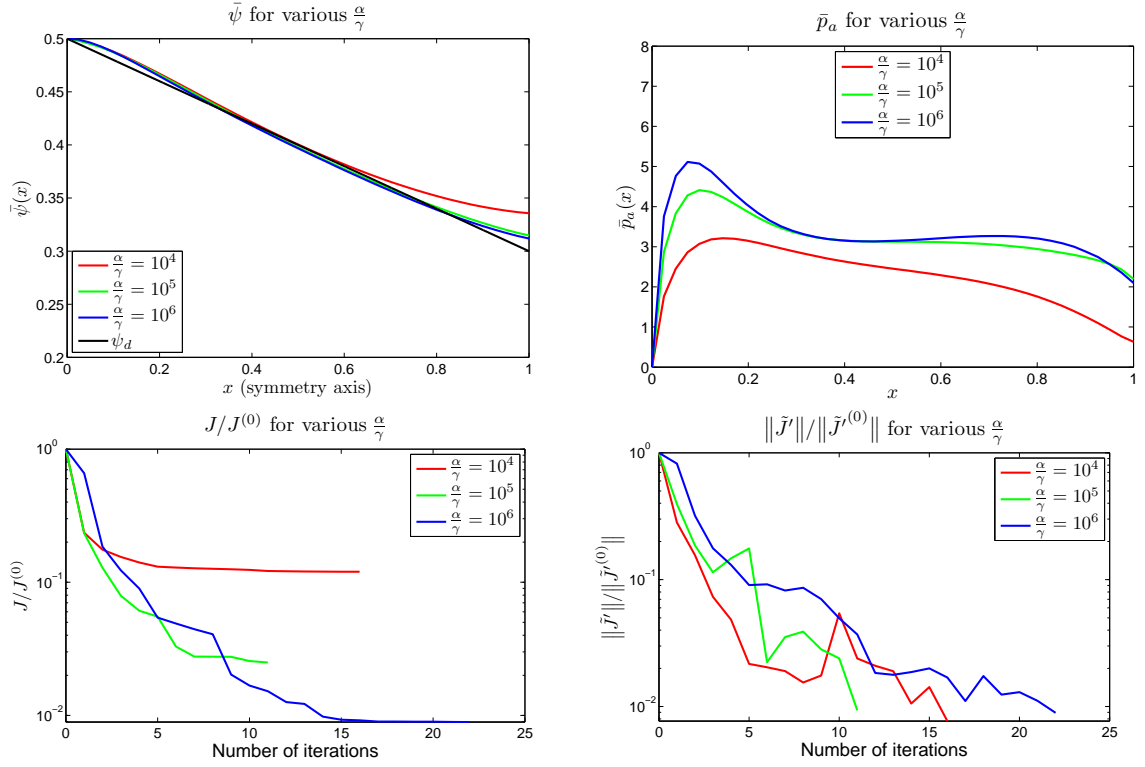
The computational costs for both optimization approaches arise mainly from moving and adapting the mesh. In **Freefem++** the moving and (re-)meshing routine takes approximately thrice as long as a FEM-solve of the Stokes equations, the effort for evaluating ODEs is in comparison irrelevant. Remeshing is generally required in every Armijo step of a BFGS iteration, which involves the solving of the forward problem to evaluate the new cost function and update the control. Whereas the forward solve for the free boundary value problem in (P1) implies several remeshing procedures due to the fixed point iteration used in algorithm 2, it is just one for (P2). In table 5.2 the number of BFGS iterations, the mean number of Armijo steps, forward and backward Stokes solves needed per BFGS iteration are listed for the exemplary setting of the figures 5.2b and 5.3b. The CPU-time is clearly correlated to the product of BFGS iterations and forward Stokes solves, as expected. Moreover, the number of BFGS iterations rise for decreasing regularization in the cost function (smaller  $\gamma$ ). The strategy of treating the graph as control variable yields a speed-up of factor 4 in CPU-time which makes it obviously much more efficient.

## 6. CONCLUSION

In this paper we have presented and discussed two strategies for the adjoint-based optimization of a free surface Stokes flow via an outer pressure. They differ in the treatment of the free boundary represented by graphs as either state or control variable (i.e. state- and control-approach). The numerical investigations show that the control-approach is much more efficient since it avoids the time-consuming and costly remeshing within the fixed point iteration that is needed to solve the free boundary value problem as forward problem in the state-approach. This yields an evident speed-up of the optimization. However, it also turns out that the control-approach is less sensitive to variations of the outer pressure which is not surprising since the free boundary is just incorporated in the cost function as penalty term.

In view of the application further research should address time-dependent problems. In particular, more sophisticated flow equations like the Navier-Stokes equations with surface tension, temperature dependency and body forces play an important role for film casting processes. Furthermore the optimization of a free surface which cannot be described by a graph stays an interesting topic of research [1, 10].



## REFERENCES

- [1] M. K. Bernauer and R. Herzog. Optimal control of the classical two-phase Stefan problem in level set formulation. *Preprint TU Chemnitz*, 2010.
- [2] S. d’Halewyu, J. F. Agassant, and Y. Demay. Numerical simulation of the cast film process. *Polym. Eng. Sci.*, 30(6):335–340, 1990.
- [3] A. Ern and J. L. Guermond. *Theory and practice of finite elements*. Springer, 2004.
- [4] A. Fortin, P. Carrier, and Y. Demay. Numerical simulation of coextrusion and film casting. *Int. J. Numer. Meth. Fluids*, 20:31–57, 1995.
- [5] F. Hecht, O. Pironneau, A. Le Hyaric, and K. Ohtsuka. *Freefem++ Manual*, 3rd edition, 2009. <http://www.freefem.org/ff++/ftp/freefem++doc.pdf>.
- [6] M. Hinze, R. Pinnau, M. Ulbrich, and S. Ulbrich. *Optimization with PDE constraints*. Springer, 2008.
- [7] M. Hinze and S. Ziegenbalg. Optimal control of the free boundary in a two-phase Stefan problem. *J. Comput. Phys.*, 223(2):657–684, 2007.
- [8] M. Hinze and S. Ziegenbalg. Optimal control of the free boundary in a two-phase Stefan problem with flow driven by convection. *Z. Angew. Math. Mech.*, 87(6):430–448, 2007.
- [9] C. T. Kelley. *Iterative methods for optimization*. SIAM, 1999.
- [10] B. Mohammadi and O. Pironneau. *Applied shape optimization for fluids*. Oxford University Press, 2001.
- [11] J. Nocedal and S. J. Wright. *Numerical optimization*. Springer, 2006.
- [12] S. Repke. *Different adjoint-based optimization approaches for free surface Stokes flows: Theory and numerics*. PhD thesis, TU Kaiserslautern, 2010, in preparation.
- [13] S. Repke and N. Marheineke. On optimal control of a free surface flow. *Proc. Appl. Math. Mech.*, 9(1):607–608, 2010.
- [14] K. Sakaki, R. Katsumoto, T. Kajiwara, and K. Funatsu. Three-dimensional flow simulation of a film-casting process. *Polym. Eng. Sci.*, 36(13):1821–1831, 1996.
- [15] K. Selvanayagam, T. Götz, S. Sundar, and V. Vetrivel. Optimal control of film casting processes. *Int. J. Numer. Meth. Fluids*, 59(10):1111–1124, 2009.
- [16] D. Silagy, Y. Demay, and J. F. Agassant. Numerical simulation of the film casting process. *Int. J. Numer. Meth. Fluids*, 30:1–18, 1999.
- [17] F. Tröltzsch. *Optimale Steuerung partieller Differentialgleichungen: Theorie, Verfahren und Anwendungen*. Vieweg, 2005.
- [18] O. Volkov and B. Protas. An inverse model for a free-boundary problem with a contact line: Steady case. *J. Comput. Phys.*, 228:4893–4910, 2009.
- [19] O. Volkov, B. Protas, W. Liao, and D. W. Glander. Adjoint-based optimization of thermo-fluid phenomena in welding processes. *J. Eng. Math.*, 65(3):201–220, 2009.

S. REPKE, FRAUNHOFER ITWM, KAISERSLAUTERN, GERMANY  
*E-mail address:* `repke@itwm.fhg.de`

N. MARHEINEKE, UNIVERSITÄT KAISERSLAUTERN, FACHBEREICH MATHEMATIK, KAISERSLAUTERN, GERMANY  
*E-mail address:* `marheineke@mathematik.uni-kl.de`

R. PINNAU, UNIVERSITÄT KAISERSLAUTERN, FACHBEREICH MATHEMATIK, KAISERSLAUTERN, GERMANY  
*E-mail address:* `pinnau@mathematik.uni-kl.de`

# Published reports of the Fraunhofer ITWM

The PDF-files of the following reports are available under:

[www.itwm.fraunhofer.de/de/zentral\\_\\_berichte/berichte](http://www.itwm.fraunhofer.de/de/zentral__berichte/berichte)

1. D. Hietel, K. Steiner, J. Struckmeier  
**A Finite - Volume Particle Method for Compressible Flows**  
(19 pages, 1998)
2. M. Feldmann, S. Seibold  
**Damage Diagnosis of Rotors: Application of Hilbert Transform and Multi-Hypothesis Testing**  
Keywords: Hilbert transform, damage diagnosis, Kalman filtering, non-linear dynamics  
(23 pages, 1998)
3. Y. Ben-Haim, S. Seibold  
**Robust Reliability of Diagnostic Multi-Hypothesis Algorithms: Application to Rotating Machinery**  
Keywords: Robust reliability, convex models, Kalman filtering, multi-hypothesis diagnosis, rotating machinery, crack diagnosis  
(24 pages, 1998)
4. F.-Th. Lentens, N. Siedow  
**Three-dimensional Radiative Heat Transfer in Glass Cooling Processes**  
(23 pages, 1998)
5. A. Klar, R. Wegener  
**A hierarchy of models for multilane vehicular traffic**  
**Part I: Modeling**  
(23 pages, 1998)  
**Part II: Numerical and stochastic investigations**  
(17 pages, 1998)
6. A. Klar, N. Siedow  
**Boundary Layers and Domain Decomposition for Radiative Heat Transfer and Diffusion Equations: Applications to Glass Manufacturing Processes**  
(24 pages, 1998)
7. I. Choquet  
**Heterogeneous catalysis modelling and numerical simulation in rarified gas flows**  
**Part I: Coverage locally at equilibrium**  
(24 pages, 1998)
8. J. Ohser, B. Steinbach, C. Lang  
**Efficient Texture Analysis of Binary Images**  
(17 pages, 1998)
9. J. Orlik  
**Homogenization for viscoelasticity of the integral type with aging and shrinkage**  
(20 pages, 1998)
10. J. Mohring  
**Helmholtz Resonators with Large Aperture**  
(21 pages, 1998)
11. H. W. Hamacher, A. Schöbel  
**On Center Cycles in Grid Graphs**  
(15 pages, 1998)
12. H. W. Hamacher, K.-H. Küfer  
**Inverse radiation therapy planning - a multiple objective optimisation approach**  
(14 pages, 1999)
13. C. Lang, J. Ohser, R. Hilfer  
**On the Analysis of Spatial Binary Images**  
(20 pages, 1999)
14. M. Junk  
**On the Construction of Discrete Equilibrium Distributions for Kinetic Schemes**  
(24 pages, 1999)
15. M. Junk, S. V. Raghurame Rao  
**A new discrete velocity method for Navier-Stokes equations**  
(20 pages, 1999)
16. H. Neunzert  
**Mathematics as a Key to Key Technologies**  
(39 pages (4 PDF-Files), 1999)
17. J. Ohser, K. Sandau  
**Considerations about the Estimation of the Size Distribution in Wicksell's Corpuscle Problem**  
(18 pages, 1999)
18. E. Carrizosa, H. W. Hamacher, R. Klein, S. Nickel  
**Solving nonconvex planar location problems by finite dominating sets**  
Keywords: Continuous Location, Polyhedral Gauges, Finite Dominating Sets, Approximation, Sandwich Algorithm, Greedy Algorithm  
(19 pages, 2000)
19. A. Becker  
**A Review on Image Distortion Measures**  
Keywords: Distortion measure, human visual system  
(26 pages, 2000)
20. H. W. Hamacher, M. Labbé, S. Nickel, T. Sonneborn  
**Polyhedral Properties of the Uncapacitated Multiple Allocation Hub Location Problem**  
Keywords: integer programming, hub location, facility location, valid inequalities, facets, branch and cut  
(21 pages, 2000)
21. H. W. Hamacher, A. Schöbel  
**Design of Zone Tariff Systems in Public Transportation**  
(30 pages, 2001)
22. D. Hietel, M. Junk, R. Keck, D. Teleaga  
**The Finite-Volume-Particle Method for Conservation Laws**  
(16 pages, 2001)
23. T. Bender, H. Hennes, J. Kalcsics, M. T. Melo, S. Nickel  
**Location Software and Interface with GIS and Supply Chain Management**  
Keywords: facility location, software development, geographical information systems, supply chain management  
(48 pages, 2001)
24. H. W. Hamacher, S. A. Tjandra  
**Mathematical Modelling of Evacuation Problems: A State of Art**  
(44 pages, 2001)
25. J. Kuhnert, S. Tiwari  
**Grid free method for solving the Poisson equation**  
Keywords: Poisson equation, Least squares method, Grid free method  
(19 pages, 2001)
26. T. Götz, H. Rave, D. Reinel-Bitzer, K. Steiner, H. Tiemeier  
**Simulation of the fiber spinning process**  
Keywords: Melt spinning, fiber model, Lattice Boltzmann, CFD  
(19 pages, 2001)
27. A. Zemitis  
**On interaction of a liquid film with an obstacle**  
Keywords: impinging jets, liquid film, models, numerical solution, shape  
(22 pages, 2001)
28. I. Ginzburg, K. Steiner  
**Free surface lattice-Boltzmann method to model the filling of expanding cavities by Bingham Fluids**  
Keywords: Generalized LBE, free-surface phenomena, interface boundary conditions, filling processes, Bingham viscoplastic model, regularized models  
(22 pages, 2001)
29. H. Neunzert  
**»Denn nichts ist für den Menschen als Menschen etwas wert, was er nicht mit Leidenschaft tun kann«**  
**Vortrag anlässlich der Verleihung des Akademiepreises des Landes Rheinland-Pfalz am 21.11.2001**  
Keywords: Lehre, Forschung, angewandte Mathematik, Mehrrskalalanalyse, Strömungsmechanik  
(18 pages, 2001)
30. J. Kuhnert, S. Tiwari  
**Finite pointset method based on the projection method for simulations of the incompressible Navier-Stokes equations**  
Keywords: Incompressible Navier-Stokes equations, Meshfree method, Projection method, Particle scheme, Least squares approximation  
AMS subject classification: 76D05, 76M28  
(25 pages, 2001)
31. R. Korn, M. Krekel  
**Optimal Portfolios with Fixed Consumption or Income Streams**  
Keywords: Portfolio optimisation, stochastic control, HJB equation, discretisation of control problems  
(23 pages, 2002)
32. M. Krekel  
**Optimal portfolios with a loan dependent credit spread**  
Keywords: Portfolio optimisation, stochastic control, HJB equation, credit spread, log utility, power utility, non-linear wealth dynamics  
(25 pages, 2002)
33. J. Ohser, W. Nagel, K. Schladitz  
**The Euler number of discretized sets – on the choice of adjacency in homogeneous lattices**  
Keywords: image analysis, Euler number, neighborhood relationships, cuboidal lattice  
(32 pages, 2002)

34. I. Ginzburg, K. Steiner  
**Lattice Boltzmann Model for Free-Surface flow and Its Application to Filling Process in Casting**  
Keywords: Lattice Boltzmann models; free-surface phenomena; interface boundary conditions; filling processes; injection molding; volume of fluid method; interface boundary conditions; advection-schemes; up-wind-schemes (54 pages, 2002)
35. M. Günther, A. Klar, T. Materne, R. Wegener  
**Multivalued fundamental diagrams and stop and go waves for continuum traffic equations**  
Keywords: traffic flow, macroscopic equations, kinetic derivation, multivalued fundamental diagram, stop and go waves, phase transitions (25 pages, 2002)
36. S. Feldmann, P. Lang, D. Prätzel-Wolters  
**Parameter influence on the zeros of network determinants**  
Keywords: Networks, Equicofactor matrix polynomials, Realization theory, Matrix perturbation theory (30 pages, 2002)
37. K. Koch, J. Ohser, K. Schladitz  
**Spectral theory for random closed sets and estimating the covariance via frequency space**  
Keywords: Random set, Bartlett spectrum, fast Fourier transform, power spectrum (28 pages, 2002)
38. D. d'Humières, I. Ginzburg  
**Multi-reflection boundary conditions for lattice Boltzmann models**  
Keywords: lattice Boltzmann equation, boundary conditions, bounce-back rule, Navier-Stokes equation (72 pages, 2002)
39. R. Korn  
**Elementare Finanzmathematik**  
Keywords: Finanzmathematik, Aktien, Optionen, Portfolio-Optimierung, Börse, Lehrerweiterbildung, Mathematikunterricht (98 pages, 2002)
40. J. Kallrath, M. C. Müller, S. Nickel  
**Batch Presorting Problems: Models and Complexity Results**  
Keywords: Complexity theory, Integer programming, Assignment, Logistics (19 pages, 2002)
41. J. Linn  
**On the frame-invariant description of the phase space of the Folgar-Tucker equation**  
Key words: fiber orientation, Folgar-Tucker equation, injection molding (5 pages, 2003)
42. T. Hanne, S. Nickel  
**A Multi-Objective Evolutionary Algorithm for Scheduling and Inspection Planning in Software Development Projects**  
Key words: multiple objective programming, project management and scheduling, software development, evolutionary algorithms, efficient set (29 pages, 2003)
43. T. Bortfeld, K.-H. Küfer, M. Monz, A. Scherrer, C. Thieke, H. Trinkaus  
**Intensity-Modulated Radiotherapy - A Large Scale Multi-Criteria Programming Problem**  
Keywords: multiple criteria optimization, representative systems of Pareto solutions, adaptive triangulation, clustering and disaggregation techniques, visualization of Pareto solutions, medical physics, external beam radiotherapy planning, intensity modulated radiotherapy (31 pages, 2003)
44. T. Halfmann, T. Wichmann  
**Overview of Symbolic Methods in Industrial Analog Circuit Design**  
Keywords: CAD, automated analog circuit design, symbolic analysis, computer algebra, behavioral modeling, system simulation, circuit sizing, macro modeling, differential-algebraic equations, index (17 pages, 2003)
45. S. E. Mikhailov, J. Orlik  
**Asymptotic Homogenisation in Strength and Fatigue Durability Analysis of Composites**  
Keywords: multiscale structures, asymptotic homogenization, strength, fatigue, singularity, non-local conditions (14 pages, 2003)
46. P. Domínguez-Marín, P. Hansen, N. Mladenović, S. Nickel  
**Heuristic Procedures for Solving the Discrete Ordered Median Problem**  
Keywords: genetic algorithms, variable neighborhood search, discrete facility location (31 pages, 2003)
47. N. Boland, P. Domínguez-Marín, S. Nickel, J. Puerto  
**Exact Procedures for Solving the Discrete Ordered Median Problem**  
Keywords: discrete location, Integer programming (41 pages, 2003)
48. S. Feldmann, P. Lang  
**Padé-like reduction of stable discrete linear systems preserving their stability**  
Keywords: Discrete linear systems, model reduction, stability, Hankel matrix, Stein equation (16 pages, 2003)
49. J. Kallrath, S. Nickel  
**A Polynomial Case of the Batch Presorting Problem**  
Keywords: batch presorting problem, online optimization, competitive analysis, polynomial algorithms, logistics (17 pages, 2003)
50. T. Hanne, H. L. Trinkaus  
**knowCube for MCDM – Visual and Interactive Support for Multicriteria Decision Making**  
Key words: Multicriteria decision making, knowledge management, decision support systems, visual interfaces, interactive navigation, real-life applications. (26 pages, 2003)
51. O. Iliev, V. Laptev  
**On Numerical Simulation of Flow Through Oil Filters**  
Keywords: oil filters, coupled flow in plain and porous media, Navier-Stokes, Brinkman, numerical simulation (8 pages, 2003)
52. W. Dörfler, O. Iliev, D. Stoyanov, D. Vassileva  
**On a Multigrid Adaptive Refinement Solver for Saturated Non-Newtonian Flow in Porous Media**  
Keywords: Nonlinear multigrid, adaptive refinement, non-Newtonian flow in porous media (17 pages, 2003)
53. S. Kruse  
**On the Pricing of Forward Starting Options under Stochastic Volatility**  
Keywords: Option pricing, forward starting options, Heston model, stochastic volatility, cliquet options (11 pages, 2003)
54. O. Iliev, D. Stoyanov  
**Multigrid – adaptive local refinement solver for incompressible flows**  
Keywords: Navier-Stokes equations, incompressible flow, projection-type splitting, SIMPLE, multigrid methods, adaptive local refinement, lid-driven flow in a cavity (37 pages, 2003)
55. V. Starikovicus  
**The multiphase flow and heat transfer in porous media**  
Keywords: Two-phase flow in porous media, various formulations, global pressure, multiphase mixture model, numerical simulation (30 pages, 2003)
56. P. Lang, A. Sarishvili, A. Wirsén  
**Blocked neural networks for knowledge extraction in the software development process**  
Keywords: Blocked Neural Networks, Nonlinear Regression, Knowledge Extraction, Code Inspection (21 pages, 2003)
57. H. Knaf, P. Lang, S. Zeiser  
**Diagnosis aiding in Regulation Thermography using Fuzzy Logic**  
Keywords: fuzzy logic, knowledge representation, expert system (22 pages, 2003)
58. M. T. Melo, S. Nickel, F. Saldanha da Gama  
**Largescale models for dynamic multi-commodity capacitated facility location**  
Keywords: supply chain management, strategic planning, dynamic location, modeling (40 pages, 2003)
59. J. Orlik  
**Homogenization for contact problems with periodically rough surfaces**  
Keywords: asymptotic homogenization, contact problems (28 pages, 2004)
60. A. Scherrer, K.-H. Küfer, M. Monz, F. Alonso, T. Bortfeld  
**IMRT planning on adaptive volume structures – a significant advance of computational complexity**  
Keywords: Intensity-modulated radiation therapy (IMRT), inverse treatment planning, adaptive volume structures, hierarchical clustering, local refinement, adaptive clustering, convex programming, mesh generation, multi-grid methods (24 pages, 2004)
61. D. Kehrwald  
**Parallel lattice Boltzmann simulation of complex flows**  
Keywords: Lattice Boltzmann methods, parallel computing, microstructure simulation, virtual material design, pseudo-plastic fluids, liquid composite moulding (12 pages, 2004)
62. O. Iliev, J. Linn, M. Moog, D. Niedziela, V. Starikovicus  
**On the Performance of Certain Iterative Solvers for Coupled Systems Arising in Discretization of Non-Newtonian Flow Equations**

Keywords: Performance of iterative solvers, Preconditioners, Non-Newtonian flow (17 pages, 2004)

63. R. Ciegis, O. Iliev, S. Rief, K. Steiner  
**On Modelling and Simulation of Different Regimes for Liquid Polymer Moulding**  
Keywords: Liquid Polymer Moulding, Modelling, Simulation, Infiltration, Front Propagation, non-Newtonian flow in porous media (43 pages, 2004)

64. T. Hanne, H. Neu  
**Simulating Human Resources in Software Development Processes**  
Keywords: Human resource modeling, software process, productivity, human factors, learning curve (14 pages, 2004)

65. O. Iliev, A. Mikelic, P. Popov  
**Fluid structure interaction problems in deformable porous media: Toward permeability of deformable porous media**  
Keywords: fluid-structure interaction, deformable porous media, upscaling, linear elasticity, stokes, finite elements (28 pages, 2004)

66. F. Gaspar, O. Iliev, F. Lisbona, A. Naumovich, P. Vabishchevich  
**On numerical solution of 1-D poroelasticity equations in a multilayered domain**  
Keywords: poroelasticity, multilayered material, finite volume discretization, MAC type grid (41 pages, 2004)

67. J. Ohser, K. Schladitz, K. Koch, M. Nöthe  
**Diffraction by image processing and its application in materials science**  
Keywords: porous microstructure, image analysis, random set, fast Fourier transform, power spectrum, Bartlett spectrum (13 pages, 2004)

68. H. Neunzert  
**Mathematics as a Technology: Challenges for the next 10 Years**  
Keywords: applied mathematics, technology, modelling, simulation, visualization, optimization, glass processing, spinning processes, fiber-fluid interaction, turbulence effects, topological optimization, multicriteria optimization, Uncertainty and Risk, financial mathematics, Malliavin calculus, Monte-Carlo methods, virtual material design, filtration, bio-informatics, system biology (29 pages, 2004)

69. R. Ewing, O. Iliev, R. Lazarov, A. Naumovich  
**On convergence of certain finite difference discretizations for 1D poroelasticity interface problems**  
Keywords: poroelasticity, multilayered material, finite volume discretizations, MAC type grid, error estimates (26 pages, 2004)

70. W. Dörfler, O. Iliev, D. Stoyanov, D. Vassileva  
**On Efficient Simulation of Non-Newtonian Flow in Saturated Porous Media with a Multigrid Adaptive Refinement Solver**  
Keywords: Nonlinear multigrid, adaptive renement, non-Newtonian in porous media (25 pages, 2004)

71. J. Kalcsics, S. Nickel, M. Schröder  
**Towards a Unified Territory Design Approach – Applications, Algorithms and GIS Integration**  
Keywords: territory design, political districting, sales territory alignment, optimization algorithms, Geographical Information Systems (40 pages, 2005)

72. K. Schladitz, S. Peters, D. Reinelt-Bitzer, A. Wiegmann, J. Ohser  
**Design of acoustic trim based on geometric modeling and flow simulation for non-woven**  
Keywords: random system of fibers, Poisson line process, flow resistivity, acoustic absorption, Lattice-Boltzmann method, non-woven (21 pages, 2005)

73. V. Rutka, A. Wiegmann  
**Explicit Jump Immersed Interface Method for virtual material design of the effective elastic moduli of composite materials**  
Keywords: virtual material design, explicit jump immersed interface method, effective elastic moduli, composite materials (22 pages, 2005)

74. T. Hanne  
**Eine Übersicht zum Scheduling von Baustellen**  
Keywords: Projektplanung, Scheduling, Bauplanung, Bauindustrie (32 pages, 2005)

75. J. Linn  
**The Folgar-Tucker Model as a Differential Algebraic System for Fiber Orientation Calculation**  
Keywords: fiber orientation, Folgar-Tucker model, invariants, algebraic constraints, phase space, trace stability (15 pages, 2005)

76. M. Speckert, K. Dreßler, H. Mauch, A. Lion, G. J. Wierda  
**Simulation eines neuartigen Prüfsystems für Achserprobungen durch MKS-Modellierung einschließlich Regelung**  
Keywords: virtual test rig, suspension testing, multibody simulation, modeling hexapod test rig, optimization of test rig configuration (20 pages, 2005)

77. K.-H. Küfer, M. Monz, A. Scherrer, P. Süß, F. Alonso, A. S. A. Sultan, Th. Bortfeld, D. Craft, Chr. Thieke  
**Multicriteria optimization in intensity modulated radiotherapy planning**  
Keywords: multicriteria optimization, extreme solutions, real-time decision making, adaptive approximation schemes, clustering methods, IMRT planning, reverse engineering (51 pages, 2005)

78. S. Amstutz, H. Andrä  
**A new algorithm for topology optimization using a level-set method**  
Keywords: shape optimization, topology optimization, topological sensitivity, level-set (22 pages, 2005)

79. N. Ettrich  
**Generation of surface elevation models for urban drainage simulation**  
Keywords: Flooding, simulation, urban elevation models, laser scanning (22 pages, 2005)

80. H. Andrä, J. Linn, I. Matei, I. Shklyar, K. Steiner, E. Teichmann  
**OPTCAST – Entwicklung adäquater Strukturoptimierungsverfahren für Gießereien Technischer Bericht (KURZFASSUNG)**  
Keywords: Topologieoptimierung, Level-Set-Methode, Gießprozesssimulation, Gießtechnische Restriktionen, CAE-Kette zur Strukturoptimierung (77 pages, 2005)

81. N. Marheineke, R. Wegener  
**Fiber Dynamics in Turbulent Flows Part I: General Modeling Framework**  
Keywords: fiber-fluid interaction; Cosserat rod; turbulence modeling; Kolmogorov's energy spectrum; double-velocity correlations; differentiable Gaussian fields (20 pages, 2005)

**Part II: Specific Taylor Drag**  
Keywords: flexible fibers;  $k-\epsilon$  turbulence model; fiber-turbulence interaction scales; air drag; random Gaussian aerodynamic force; white noise; stochastic differential equations; ARMA process (18 pages, 2005)

82. C. H. Lampert, O. Wirjadi  
**An Optimal Non-Orthogonal Separation of the Anisotropic Gaussian Convolution Filter**  
Keywords: Anisotropic Gaussian filter, linear filtering, orientation space, nD image processing, separable filters (25 pages, 2005)

83. H. Andrä, D. Stoyanov  
**Error indicators in the parallel finite element solver for linear elasticity DDFEM**  
Keywords: linear elasticity, finite element method, hierarchical shape functions, domain decomposition, parallel implementation, a posteriori error estimates (21 pages, 2006)

84. M. Schröder, I. Solchenbach  
**Optimization of Transfer Quality in Regional Public Transit**  
Keywords: public transit, transfer quality, quadratic assignment problem (16 pages, 2006)

85. A. Naumovich, F. J. Gaspar  
**On a multigrid solver for the three-dimensional Biot poroelasticity system in multilayered domains**  
Keywords: poroelasticity, interface problem, multigrid, operator-dependent prolongation (11 pages, 2006)

86. S. Panda, R. Wegener, N. Marheineke  
**Slender Body Theory for the Dynamics of Curved Viscous Fibers**  
Keywords: curved viscous fibers; fluid dynamics; Navier-Stokes equations; free boundary value problem; asymptotic expansions; slender body theory (14 pages, 2006)

87. E. Ivanov, H. Andrä, A. Kudryavtsev  
**Domain Decomposition Approach for Automatic Parallel Generation of Tetrahedral Grids**  
Key words: Grid Generation, Unstructured Grid, Delaunay Triangulation, Parallel Programming, Domain Decomposition, Load Balancing (18 pages, 2006)

88. S. Tiwari, S. Antonov, D. Hietel, J. Kuhnert, R. Wegener  
**A Meshfree Method for Simulations of Interactions between Fluids and Flexible Structures**  
Key words: Meshfree Method, FPM, Fluid Structure Interaction, Sheet of Paper, Dynamical Coupling (16 pages, 2006)

89. R. Ciegis, O. Iliev, V. Starikovicius, K. Steiner  
**Numerical Algorithms for Solving Problems of Multiphase Flows in Porous Media**  
Keywords: nonlinear algorithms, finite-volume method, software tools, porous media, flows (16 pages, 2006)

90. D. Niedziela, O. Iliev, A. Latz  
**On 3D Numerical Simulations of Viscoelastic Fluids**  
Keywords: non-Newtonian fluids, anisotropic viscosity, integral constitutive equation  
(18 pages, 2006)
91. A. Winterfeld  
**Application of general semi-infinite Programming to Lapidary Cutting Problems**  
Keywords: large scale optimization, nonlinear programming, general semi-infinite optimization, design centering, clustering  
(26 pages, 2006)
92. J. Orlik, A. Ostrovska  
**Space-Time Finite Element Approximation and Numerical Solution of Hereditary Linear Viscoelasticity Problems**  
Keywords: hereditary viscoelasticity; kern approximation by interpolation; space-time finite element approximation, stability and a priori estimate  
(24 pages, 2006)
93. V. Rutka, A. Wiegmann, H. Andrä  
**EJIM for Calculation of effective Elastic Moduli in 3D Linear Elasticity**  
Keywords: Elliptic PDE, linear elasticity, irregular domain, finite differences, fast solvers, effective elastic moduli  
(24 pages, 2006)
94. A. Wiegmann, A. Zemitis  
**EJ-HEAT: A Fast Explicit Jump Harmonic Averaging Solver for the Effective Heat Conductivity of Composite Materials**  
Keywords: Stationary heat equation, effective thermal conductivity, explicit jump, discontinuous coefficients, virtual material design, microstructure simulation, EJ-HEAT  
(21 pages, 2006)
95. A. Naumovich  
**On a finite volume discretization of the three-dimensional Biot poroelasticity system in multilayered domains**  
Keywords: Biot poroelasticity system, interface problems, finite volume discretization, finite difference method  
(21 pages, 2006)
96. M. Krekel, J. Wenzel  
**A unified approach to Credit Default Swap-tion and Constant Maturity Credit Default Swap valuation**  
Keywords: LIBOR market model, credit risk, Credit Default Swap-tion, Constant Maturity Credit Default Swap-method  
(43 pages, 2006)
97. A. Dreyer  
**Interval Methods for Analog Circuits**  
Keywords: interval arithmetic, analog circuits, tolerance analysis, parametric linear systems, frequency response, symbolic analysis, CAD, computer algebra  
(36 pages, 2006)
98. N. Weigel, S. Weihe, G. Bitsch, K. Dreßler  
**Usage of Simulation for Design and Optimization of Testing**  
Keywords: Vehicle test rigs, MBS, control, hydraulics, testing philosophy  
(14 pages, 2006)
99. H. Lang, G. Bitsch, K. Dreßler, M. Speckert  
**Comparison of the solutions of the elastic and elastoplastic boundary value problems**  
Keywords: Elastic BVP, elastoplastic BVP, variational inequalities, rate-independency, hysteresis, linear kinematic hardening, stop- and play-operator  
(21 pages, 2006)
100. M. Speckert, K. Dreßler, H. Mauch  
**MBS Simulation of a hexapod based suspension test rig**  
Keywords: Test rig, MBS simulation, suspension, hydraulics, controlling, design optimization  
(12 pages, 2006)
101. S. Azizi Sultan, K.-H. Küfer  
**A dynamic algorithm for beam orientations in multicriteria IMRT planning**  
Keywords: radiotherapy planning, beam orientation optimization, dynamic approach, evolutionary algorithm, global optimization  
(14 pages, 2006)
102. T. Götz, A. Klar, N. Marheineke, R. Wegener  
**A Stochastic Model for the Fiber Lay-down Process in the Nonwoven Production**  
Keywords: fiber dynamics, stochastic Hamiltonian system, stochastic averaging  
(17 pages, 2006)
103. Ph. Süß, K.-H. Küfer  
**Balancing control and simplicity: a variable aggregation method in intensity modulated radiation therapy planning**  
Keywords: IMRT planning, variable aggregation, clustering methods  
(22 pages, 2006)
104. A. Beaudry, G. Laporte, T. Melo, S. Nickel  
**Dynamic transportation of patients in hospitals**  
Keywords: in-house hospital transportation, dial-a-ride, dynamic mode, tabu search  
(37 pages, 2006)
105. Th. Hanne  
**Applying multiobjective evolutionary algorithms in industrial projects**  
Keywords: multiobjective evolutionary algorithms, discrete optimization, continuous optimization, electronic circuit design, semi-infinite programming, scheduling  
(18 pages, 2006)
106. J. Franke, S. Halim  
**Wild bootstrap tests for comparing signals and images**  
Keywords: wild bootstrap test, texture classification, textile quality control, defect detection, kernel estimate, nonparametric regression  
(13 pages, 2007)
107. Z. Drezner, S. Nickel  
**Solving the ordered one-median problem in the plane**  
Keywords: planar location, global optimization, ordered median, big triangle small triangle method, bounds, numerical experiments  
(21 pages, 2007)
108. Th. Götz, A. Klar, A. Unterreiter, R. Wegener  
**Numerical evidence for the non-existing of solutions of the equations describing rotational fiber spinning**  
Keywords: rotational fiber spinning, viscous fibers, boundary value problem, existence of solutions  
(11 pages, 2007)
109. Ph. Süß, K.-H. Küfer  
**Smooth intensity maps and the Bortfeld-Boyer sequencer**  
Keywords: probabilistic analysis, intensity modulated radiotherapy treatment (IMRT), IMRT plan application, step-and-shoot sequencing  
(8 pages, 2007)
110. E. Ivanov, O. Gluchshenko, H. Andrä, A. Kudryavtsev  
**Parallel software tool for decomposing and meshing of 3d structures**  
Keywords: a-priori domain decomposition, unstructured grid, Delaunay mesh generation  
(14 pages, 2007)
111. O. Iliev, R. Lazarov, J. Willems  
**Numerical study of two-grid preconditioners for 1d elliptic problems with highly oscillating discontinuous coefficients**  
Keywords: two-grid algorithm, oscillating coefficients, preconditioner  
(20 pages, 2007)
112. L. Bonilla, T. Götz, A. Klar, N. Marheineke, R. Wegener  
**Hydrodynamic limit of the Fokker-Planck equation describing fiber lay-down processes**  
Keywords: stochastic differential equations, Fokker-Planck equation, asymptotic expansion, Ornstein-Uhlenbeck process  
(17 pages, 2007)
113. S. Rief  
**Modeling and simulation of the pressing section of a paper machine**  
Keywords: paper machine, computational fluid dynamics, porous media  
(41 pages, 2007)
114. R. Ciegis, O. Iliev, Z. Lakdawala  
**On parallel numerical algorithms for simulating industrial filtration problems**  
Keywords: Navier-Stokes-Brinkmann equations, finite volume discretization method, SIMPLE, parallel computing, data decomposition method  
(24 pages, 2007)
115. N. Marheineke, R. Wegener  
**Dynamics of curved viscous fibers with surface tension**  
Keywords: Slender body theory, curved viscous fibers with surface tension, free boundary value problem  
(25 pages, 2007)
116. S. Feth, J. Franke, M. Speckert  
**Resampling-Methoden zur mse-Korrektur und Anwendungen in der Betriebsfestigkeit**  
Keywords: Weibull, Bootstrap, Maximum-Likelihood, Betriebsfestigkeit  
(16 pages, 2007)
117. H. Knaf  
**Kernel Fisher discriminant functions – a concise and rigorous introduction**  
Keywords: wild bootstrap test, texture classification, textile quality control, defect detection, kernel estimate, nonparametric regression  
(30 pages, 2007)
118. O. Iliev, I. Rybak  
**On numerical upscaling for flows in heterogeneous porous media**

- Keywords: numerical upscaling, heterogeneous porous media, single phase flow, Darcy's law, multiscale problem, effective permeability, multipoint flux approximation, anisotropy (17 pages, 2007)
119. O. Iliev, I. Rybak  
**On approximation property of multipoint flux approximation method**  
Keywords: Multipoint flux approximation, finite volume method, elliptic equation, discontinuous tensor coefficients, anisotropy (15 pages, 2007)
120. O. Iliev, I. Rybak, J. Willems  
**On upscaling heat conductivity for a class of industrial problems**  
Keywords: Multiscale problems, effective heat conductivity, numerical upscaling, domain decomposition (21 pages, 2007)
121. R. Ewing, O. Iliev, R. Lazarov, I. Rybak  
**On two-level preconditioners for flow in porous media**  
Keywords: Multiscale problem, Darcy's law, single phase flow, anisotropic heterogeneous porous media, numerical upscaling, multigrid, domain decomposition, efficient preconditioner (18 pages, 2007)
122. M. Brickenstein, A. Dreyer  
**POLYBORI: A Gröbner basis framework for Boolean polynomials**  
Keywords: Gröbner basis, formal verification, Boolean polynomials, algebraic cryptanalysis, satisfiability (23 pages, 2007)
123. O. Wirjadi  
**Survey of 3d image segmentation methods**  
Keywords: image processing, 3d, image segmentation, binarization (20 pages, 2007)
124. S. Zeytun, A. Gupta  
**A Comparative Study of the Vasicek and the CIR Model of the Short Rate**  
Keywords: interest rates, Vasicek model, CIR-model, calibration, parameter estimation (17 pages, 2007)
125. G. Hanselmann, A. Sarishvili  
**Heterogeneous redundancy in software quality prediction using a hybrid Bayesian approach**  
Keywords: reliability prediction, fault prediction, non-homogeneous poisson process, Bayesian model averaging (17 pages, 2007)
126. V. Maag, M. Berger, A. Winterfeld, K.-H. Küfer  
**A novel non-linear approach to minimal area rectangular packing**  
Keywords: rectangular packing, non-overlapping constraints, non-linear optimization, regularization, relaxation (18 pages, 2007)
127. M. Monz, K.-H. Küfer, T. Bortfeld, C. Thieke  
**Pareto navigation – systematic multi-criteria-based IMRT treatment plan determination**  
Keywords: convex, interactive multi-objective optimization, intensity modulated radiotherapy planning (15 pages, 2007)
128. M. Krause, A. Scherrer  
**On the role of modeling parameters in IMRT plan optimization**  
Keywords: intensity-modulated radiotherapy (IMRT), inverse IMRT planning, convex optimization, sensitivity analysis, elasticity, modeling parameters, equivalent uniform dose (EUD) (18 pages, 2007)
129. A. Wiegmann  
**Computation of the permeability of porous materials from their microstructure by FFF-Stokes**  
Keywords: permeability, numerical homogenization, fast Stokes solver (24 pages, 2007)
130. T. Melo, S. Nickel, F. Saldanha da Gama  
**Facility Location and Supply Chain Management – A comprehensive review**  
Keywords: facility location, supply chain management, network design (54 pages, 2007)
131. T. Hanne, T. Melo, S. Nickel  
**Bringing robustness to patient flow management through optimized patient transports in hospitals**  
Keywords: Dial-a-Ride problem, online problem, case study, tabu search, hospital logistics (23 pages, 2007)
132. R. Ewing, O. Iliev, R. Lazarov, I. Rybak, J. Willems  
**An efficient approach for upscaling properties of composite materials with high contrast of coefficients**  
Keywords: effective heat conductivity, permeability of fractured porous media, numerical upscaling, fibrous insulation materials, metal foams (16 pages, 2008)
133. S. Gelareh, S. Nickel  
**New approaches to hub location problems in public transport planning**  
Keywords: integer programming, hub location, transportation, decomposition, heuristic (25 pages, 2008)
134. G. Thömmes, J. Becker, M. Junk, A. K. Vainkuntam, D. Kehrwald, A. Klar, K. Steiner, A. Wiegmann  
**A Lattice Boltzmann Method for immiscible multiphase flow simulations using the Level Set Method**  
Keywords: Lattice Boltzmann method, Level Set method, free surface, multiphase flow (28 pages, 2008)
135. J. Orlik  
**Homogenization in elasto-plasticity**  
Keywords: multiscale structures, asymptotic homogenization, nonlinear energy (40 pages, 2008)
136. J. Almqvist, H. Schmidt, P. Lang, J. Deitmer, M. Jirstrand, D. Prätzel-Wolters, H. Becker  
**Determination of interaction between MCT1 and CAII via a mathematical and physiological approach**  
Keywords: mathematical modeling; model reduction; electrophysiology; pH-sensitive microelectrodes; proton antenna (20 pages, 2008)
137. E. Savenkov, H. Andrä, O. Iliev  
**An analysis of one regularization approach for solution of pure Neumann problem**  
Keywords: pure Neumann problem, elasticity, regularization, finite element method, condition number (27 pages, 2008)
138. O. Berman, J. Kalcsics, D. Krass, S. Nickel  
**The ordered gradual covering location problem on a network**  
Keywords: gradual covering, ordered median function, network location (32 pages, 2008)
139. S. Gelareh, S. Nickel  
**Multi-period public transport design: A novel model and solution approaches**  
Keywords: Integer programming, hub location, public transport, multi-period planning, heuristics (31 pages, 2008)
140. T. Melo, S. Nickel, F. Saldanha-da-Gama  
**Network design decisions in supply chain planning**  
Keywords: supply chain design, integer programming models, location models, heuristics (20 pages, 2008)
141. C. Lautensack, A. Särkkä, J. Freitag, K. Schladitz  
**Anisotropy analysis of pressed point processes**  
Keywords: estimation of compression, isotropy test, nearest neighbour distance, orientation analysis, polar ice, Ripley's K function (35 pages, 2008)
142. O. Iliev, R. Lazarov, J. Willems  
**A Graph-Laplacian approach for calculating the effective thermal conductivity of complicated fiber geometries**  
Keywords: graph laplacian, effective heat conductivity, numerical upscaling, fibrous materials (14 pages, 2008)
143. J. Linn, T. Stephan, J. Carlsson, R. Bohlin  
**Fast simulation of quasistatic rod deformations for VR applications**  
Keywords: quasistatic deformations, geometrically exact rod models, variational formulation, energy minimization, finite differences, nonlinear conjugate gradients (7 pages, 2008)
144. J. Linn, T. Stephan  
**Simulation of quasistatic deformations using discrete rod models**  
Keywords: quasistatic deformations, geometrically exact rod models, variational formulation, energy minimization, finite differences, nonlinear conjugate gradients (9 pages, 2008)
145. J. Marburger, N. Marheineke, R. Pinnau  
**Adjoint based optimal control using mesh-less discretizations**  
Keywords: Mesh-less methods, particle methods, Eulerian-Lagrangian formulation, optimization strategies, adjoint method, hyperbolic equations (14 pages, 2008)
146. S. Desmettre, J. Gould, A. Szimayer  
**Own-company stockholding and work effort preferences of an unconstrained executive**  
Keywords: optimal portfolio choice, executive compensation (33 pages, 2008)

147. M. Berger, M. Schröder, K.-H. Küfer  
**A constraint programming approach for the two-dimensional rectangular packing problem with orthogonal orientations**  
Keywords: rectangular packing, orthogonal orientations non-overlapping constraints, constraint propagation (13 pages, 2008)
148. K. Schladitz, C. Redenbach, T. Sych, M. Godehardt  
**Microstructural characterisation of open foams using 3d images**  
Keywords: virtual material design, image analysis, open foams (30 pages, 2008)
149. E. Fernández, J. Kalcsics, S. Nickel, R. Ríos-Mercado  
**A novel territory design model arising in the implementation of the WEEE-Directive**  
Keywords: heuristics, optimization, logistics, recycling (28 pages, 2008)
150. H. Lang, J. Linn  
**Lagrangian field theory in space-time for geometrically exact Cosserat rods**  
Keywords: Cosserat rods, geometrically exact rods, small strain, large deformation, deformable bodies, Lagrangian field theory, variational calculus (19 pages, 2009)
151. K. Dreßler, M. Speckert, R. Müller, Ch. Weber  
**Customer loads correlation in truck engineering**  
Keywords: Customer distribution, safety critical components, quantile estimation, Monte-Carlo methods (11 pages, 2009)
152. H. Lang, K. Dreßler  
**An improved multiaxial stress-strain correction model for elastic FE postprocessing**  
Keywords: Jiang's model of elastoplasticity, stress-strain correction, parameter identification, automatic differentiation, least-squares optimization, Coleman-Li algorithm (6 pages, 2009)
153. J. Kalcsics, S. Nickel, M. Schröder  
**A generic geometric approach to territory design and districting**  
Keywords: Territory design, districting, combinatorial optimization, heuristics, computational geometry (32 pages, 2009)
154. Th. Fütterer, A. Klar, R. Wegener  
**An energy conserving numerical scheme for the dynamics of hyperelastic rods**  
Keywords: Cosserat rod, hyperelastic, energy conservation, finite differences (16 pages, 2009)
155. A. Wiegmann, L. Cheng, E. Glatt, O. Iliev, S. Rief  
**Design of pleated filters by computer simulations**  
Keywords: Solid-gas separation, solid-liquid separation, pleated filter, design, simulation (21 pages, 2009)
156. A. Klar, N. Marheineke, R. Wegener  
**Hierarchy of mathematical models for production processes of technical textiles**  
Keywords: Fiber-fluid interaction, slender-body theory, turbulence modeling, model reduction, stochastic differential equations, Fokker-Planck equation, asymptotic expansions, parameter identification (21 pages, 2009)
157. E. Glatt, S. Rief, A. Wiegmann, M. Knefel, E. Wegenke  
**Structure and pressure drop of real and virtual metal wire meshes**  
Keywords: metal wire mesh, structure simulation, model calibration, CFD simulation, pressure loss (7 pages, 2009)
158. S. Kruse, M. Müller  
**Pricing American call options under the assumption of stochastic dividends – An application of the Korn-Rogers model**  
Keywords: option pricing, American options, dividends, dividend discount model, Black-Scholes model (22 pages, 2009)
159. H. Lang, J. Linn, M. Arnold  
**Multibody dynamics simulation of geometrically exact Cosserat rods**  
Keywords: flexible multibody dynamics, large deformations, finite rotations, constrained mechanical systems, structural dynamics (20 pages, 2009)
160. P. Jung, S. Leyendecker, J. Linn, M. Ortiz  
**Discrete Lagrangian mechanics and geometrically exact Cosserat rods**  
Keywords: special Cosserat rods, Lagrangian mechanics, Noether's theorem, discrete mechanics, frame-indifference, holonomic constraints (14 pages, 2009)
161. M. Burger, K. Dreßler, A. Marquardt, M. Speckert  
**Calculating invariant loads for system simulation in vehicle engineering**  
Keywords: iterative learning control, optimal control theory, differential algebraic equations(DAEs) (18 pages, 2009)
162. M. Speckert, N. Ruf, K. Dreßler  
**Undesired drift of multibody models excited by measured accelerations or forces**  
Keywords: multibody simulation, full vehicle model, force-based simulation, drift due to noise (19 pages, 2009)
163. A. Streit, K. Dreßler, M. Speckert, J. Lichter, T. Zenner, P. Bach  
**Anwendung statistischer Methoden zur Erstellung von Nutzungsprofilen für die Auslegung von Mobilbaggern**  
Keywords: Nutzungsvielfalt, Kundenbeanspruchung, Bemessungsgrundlagen (13 pages, 2009)
164. I. Correia, S. Nickel, F. Saldanha-da-Gama  
**Anwendung statistischer Methoden zur Erstellung von Nutzungsprofilen für die Auslegung von Mobilbaggern**  
Keywords: Capacitated Hub Location, MIP formulations (10 pages, 2009)
165. F. Yaneva, T. Grebe, A. Scherrer  
**An alternative view on global radiotherapy optimization problems**  
Keywords: radiotherapy planning, path-connected sub-levelsets, modified gradient projection method, improving and feasible directions (14 pages, 2009)
166. J. I. Serna, M. Monz, K.-H. Küfer, C. Thieke  
**Trade-off bounds and their effect in multi-criteria IMRT planning**  
Keywords: trade-off bounds, multi-criteria optimization, IMRT, Pareto surface (15 pages, 2009)
167. W. Arne, N. Marheineke, A. Meister, R. Wegener  
**Numerical analysis of Cosserat rod and string models for viscous jets in rotational spinning processes**  
Keywords: Rotational spinning process, curved viscous fibers, asymptotic Cosserat models, boundary value problem, existence of numerical solutions (18 pages, 2009)
168. T. Melo, S. Nickel, F. Saldanha-da-Gama  
**An LP-rounding heuristic to solve a multi-period facility relocation problem**  
Keywords: supply chain design, heuristic, linear programming, rounding (37 pages, 2009)
169. I. Correia, S. Nickel, F. Saldanha-da-Gama  
**Single-allocation hub location problems with capacity choices**  
Keywords: hub location, capacity decisions, MILP formulations (27 pages, 2009)
170. S. Acar, K. Natcheva-Acar  
**A guide on the implementation of the Heath-Jarrow-Morton Two-Factor Gaussian Short Rate Model (HJM-G2++)**  
Keywords: short rate model, two factor Gaussian, G2++, option pricing, calibration (30 pages, 2009)
171. A. Szimayer, G. Dimitroff, S. Lorenz  
**A parsimonious multi-asset Heston model: calibration and derivative pricing**  
Keywords: Heston model, multi-asset, option pricing, calibration, correlation (28 pages, 2009)
172. N. Marheineke, R. Wegener  
**Modeling and validation of a stochastic drag for fibers in turbulent flows**  
Keywords: fiber-fluid interactions, long slender fibers, turbulence modelling, aerodynamic drag, dimensional analysis, data interpolation, stochastic partial differential algebraic equation, numerical simulations, experimental validations (19 pages, 2009)
173. S. Nickel, M. Schröder, J. Steeg  
**Planning for home health care services**  
Keywords: home health care, route planning, metaheuristics, constraint programming (23 pages, 2009)
174. G. Dimitroff, A. Szimayer, A. Wagner  
**Quanto option pricing in the parsimonious Heston model**  
Keywords: Heston model, multi asset, quanto options, option pricing (14 pages, 2009)
174. G. Dimitroff, A. Szimayer, A. Wagner  
**Model reduction of nonlinear problems in structural mechanics**  
Keywords: flexible bodies, FEM, nonlinear model reduction, POD (13 pages, 2009)

176. M. K. Ahmad, S. Didas, J. Iqbal  
**Using the Sharp Operator for edge detection and nonlinear diffusion**  
 Keywords: maximal function, sharp function, image processing, edge detection, nonlinear diffusion  
 (17 pages, 2009)
177. M. Speckert, N. Ruf, K. Dreßler, R. Müller, C. Weber, S. Weihe  
**Ein neuer Ansatz zur Ermittlung von Erprobungslasten für sicherheitsrelevante Bauteile**  
 Keywords: sicherheitsrelevante Bauteile, Kundenbeanspruchung, Festigkeitsverteilung, Ausfallwahrscheinlichkeit, Konfidenz, statistische Unsicherheit, Sicherheitsfaktoren  
 (16 pages, 2009)
178. J. Jegorovs  
**Wave based method: new applicability areas**  
 Keywords: Elliptic boundary value problems, inhomogeneous Helmholtz type differential equations in bounded domains, numerical methods, wave based method, uniform B-splines  
 (10 pages, 2009)
179. H. Lang, M. Arnold  
**Numerical aspects in the dynamic simulation of geometrically exact rods**  
 Keywords: Kirchhoff and Cosserat rods, geometrically exact rods, deformable bodies, multibody dynamics, partial differential algebraic equations, method of lines, time integration  
 (21 pages, 2009)
180. H. Lang  
**Comparison of quaternionic and rotation-free null space formalisms for multibody dynamics**  
 Keywords: Parametrisation of rotations, differential-algebraic equations, multibody dynamics, constrained mechanical systems, Lagrangian mechanics  
 (40 pages, 2010)
181. S. Nickel, F. Saldanha-da-Gama, H.-P. Ziegler  
**Stochastic programming approaches for risk aware supply chain network design problems**  
 Keywords: Supply Chain Management, multi-stage stochastic programming, financial decisions, risk  
 (37 pages, 2010)
182. P. Ruckdeschel, N. Horbenko  
**Robustness properties of estimators in generalized Pareto Models**  
 Keywords: global robustness, local robustness, finite sample breakdown point, generalized Pareto distribution  
 (58 pages, 2010)
183. P. Jung, S. Leyendecker, J. Linn, M. Ortiz  
**A discrete mechanics approach to Cosserat rod theory – Part 1: static equilibria**  
 Keywords: Special Cosserat rods; Lagrangian mechanics; Noether's theorem; discrete mechanics; frame-indifference; holonomic constraints; variational formulation  
 (35 pages, 2010)
184. R. Eymard, G. Printsypar  
**A proof of convergence of a finite volume scheme for modified steady Richards' equation describing transport processes in the pressing section of a paper machine**  
 Keywords: flow in porous media, steady Richards' equation, finite volume methods, convergence of approximate solution  
 (14 pages, 2010)
185. P. Ruckdeschel  
**Optimally Robust Kalman Filtering**  
 Keywords: robustness, Kalman Filter, innovation outlier, additive outlier  
 (42 pages, 2010)
186. S. Repke, N. Marheineke, R. Pinnau  
**On adjoint-based optimization of a free surface Stokes flow**  
 Keywords: film casting process, thin films, free surface Stokes flow, optimal control, Lagrange formalism  
 (13 pages, 2010)
- Status quo: June 2010